

FoodCenter

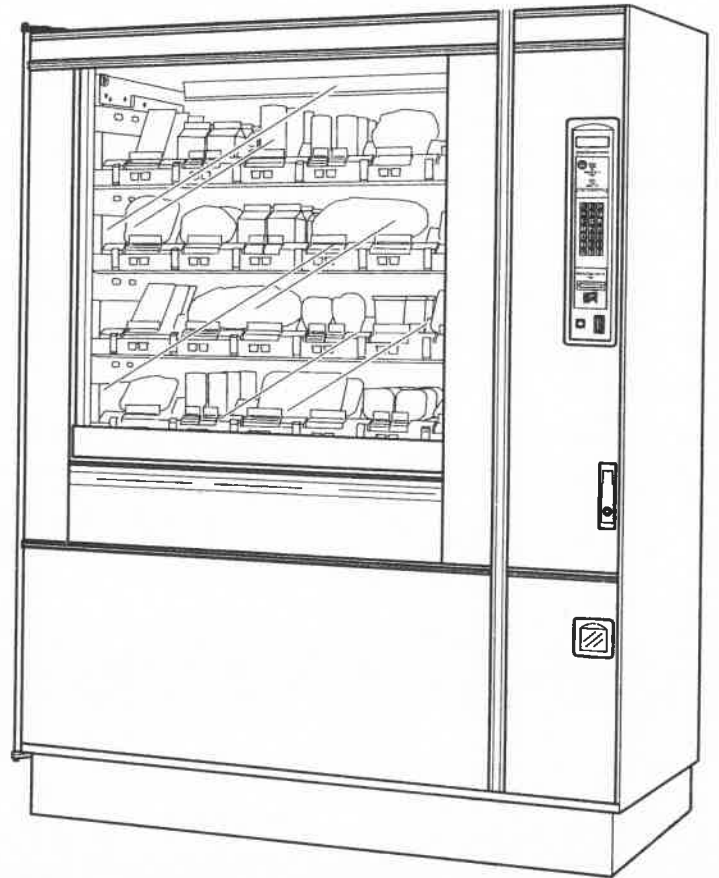

Set-Up Guide

Copyright © 11-98

4280009



CRANE- National Vendors



SECTION I. SET-UP 1

Initial Set-Up 1

 Unpack and Inspect 1

 Electrical Utility Requirements 1

 Position the Merchandiser 2

 Connect the Merchandiser to Utilities 2

 Level the Merchandiser 2

 Install the Door Lock (Optional) 3

 Home the Drive Shaft Channels 3

 Install the Coin Mechanism 4

 Open Tray Interlocks 5

 Install Trays 6

 Install the Hatch Shell 7

Prepare the Merchandiser for Vending 8

 1. Set Up the Bill Validator 9

 2. Install Selection and Price Labels 9

 3. Set Prices 9

 4. Set the Time 9

 5. Adjust Trays to Fit the Product to Be Loaded 9

 6. Load Product in the Merchandiser 9

 7. Perform Test Vends to Verify Proper Operation 9

SECTION II. PROGRAMMING 10

The Displays 11

The Function Keys 11

Other Keys 11

Control Panel Switch Functions Explained 12

Programming Flow Charts 13

Programming Procedures

 Gain Access to the Supervisor Mode 17

 Enter a New Supervisor Code 17

 Lock or Unlock Mode or Payout Keys 18

 Set Printer or Dex Options 18

 Lock or Unlock Data Clearing Access 19

 Select Printer Baud Rate 19

 Select Coin Mechanism 20

 Select Bill Validator and Options 21

 Select Display Language 22

 Select Card Reader and Options 23

 Select Monetary Options 23

 Set Up Winner Mode 25

 Set Temperature 26

 View Software Version 26

 Set the Time of Day 27

 Set the Day of the Week 27

 Set Month, Day, and Year 28

 Set Time-of-Day Inhibited Vending 28

 Set Time-of-Day Free Vending 28

 Set Time-of-Day Discount Vending 28

 Time Interval Editing 29

 Select a Standby Message 31

 Select an Out-of-Service Message 31

 Select a Freevend Message 32

 Edit Custom Messages 33

 View Machine Temperature 35



35 Payout Coins

36 Set Prices and View Maximum/Minimum Prices

37 Block or Unblock Selections

37 View Nonresetttable Sales and Vend Data

38 View Data Three Different Ways

38 View Total Paid Sales

38 View Total Paid Vends

39 Clear All Resetttable Data

39 Clear Paid Sales Data Only

39 View Amount in Coin Box

40 View Amount in Validator

40 View Freevend Sales by Time Interval

41 View Discount Sales by Time Interval

41 View Free Vends

41 View Winners

41 View Time Data

42 View Total Unpaid Sales

43 View Total Unpaid Vends

44 View Number of Test Vends

44 View Machine ID Number

45 Test Vend Selections and Verify Credit Added

45 Test the Display

46 Test the Elevator

47 Test the Solenoids

47 Test the Tray Motor

48 Test the Door Lock

48 Test the Door Motor

49 Test the Counter Wheel

49 Download Data to a PDCD

50 View Diagnostic Messages

52 Set Freevend Options

53 SECTION III. ADJUSTMENT AND REMOVAL PROCEDURES

53 Adjusting Trays for Tilt Pullout

54 Adjusting Product Dividers

55 Coupling Two Modules to Vend Together

56 Tray Cover Assembly Removal

57 Tray Module Removal and Replacement

57 Product Belt Removal and Replacement

65 SECTION IV. CLEANING, SANITATION, AND SERVICE

65 Introduction

66 Daily Service Procedures

67 Daily Cleaning and Sanitation Procedures

67 Weekly Service Procedures

67 Weekly Cleaning and Sanitation Procedures

67 Monthly Service Procedures

67 Cleaning the Coin Validator and Coin Chute

68 Cleaning the Bill Validator

INDEX - 1



SPECIFICATIONS

DIMENSIONS:	Height - 183 cm (72 in.) Width - 142.2 cm (56 in.) Depth - 109.2 cm (43 in.)
WEIGHT:	623.7 kg (1375 lbs.)
ELECTRICAL (U.S.): (INTERNATIONAL):	115 Volts AC, 60 Hertz, 12 Amps, Single Phase 230 Volts AC, 50 Hertz, 7 Amps, Single Phase
REFRIGERATION:	Compressor - 1/3 hp Refrigerant - 134a Charge - 311 g (11 oz.)
MISCELLANEOUS:	Minimum ambient temperature 5° C (41° F) Maximum ambient temperature 32° C (90° F)

FOR INDOOR USE ONLY

THIS PAGE INTENTIONALLY LEFT BLANK





SECTION I. SET-UP

INITIAL SET-UP

CAUTION

Do not connect the machine power cord or attempt to operate the merchandiser before it is completely inspected and the power supply is checked for proper voltage and grounding.

UNPACK AND INSPECT

Verify the model and part numbers with the merchandiser invoice or freight bill. Immediately report any shortage or discrepancy to the carrier.

Remove and save all shipping and packing materials until a thorough inspection has been completed.

Examine the merchandiser for dents, scratches, or other damage resulting from improper handling. If any shipping damage is detected, file an immediate claim with the carrier.

Electrical Utility Requirements

This merchandiser is supplied with a service cord for the country of use and is terminated in a grounding type plug. The wall receptacle used for this merchandiser must be properly polarized, grounded, and of the correct voltage. Operating the merchandiser from a source of low voltage will **VOID YOUR WARRANTY**. Each merchandiser should have its own electrical circuit and that circuit should be protected with a circuit breaker or fuse conforming to local regulations.

Voltage Check - Place the leads of a voltmeter across the LINE (LIVE) and NEUTRAL terminals of the wall receptacle. The voltmeter should indicate 110-130 volts ac for 120 volt, 60 Hz locations, or 220-240 volts ac for 230 volt, 50 Hz locations.

Polarity Check - Place the leads of a voltmeter across the LINE (LIVE) and GROUND terminals of the wall receptacle. The voltmeter should indicate 110-130 volts ac for 120 volt, 60 Hz locations, or 220-240 volts ac for 230 volt, 50 Hz locations.

Noise Potential Check - Place the leads of a voltmeter across the NEUTRAL and GROUND terminals of the wall receptacle. The voltmeter should indicate 0 volts ac. A measurement greater than 1.5-2.0 volts ac could result in problems for the merchandiser's electronic circuitry caused by electrical noise.

Any deviation from these requirements could result in unreliable performance from your merchandiser.



POSITION THE MERCHANTISER
 You can position this merchandiser anywhere in a bank of machines, even on the end. Leave room in front of the merchandiser for the door to open freely, and at least 6 inches behind the merchandiser for air flow to the compressor.

CONNECT THE MERCHANTISER TO UTILITIES

1. Set the MAIN POWER switch to the OFF (down) position.
2. Connect the merchandiser to the power source.

LEVEL THE MERCHANTISER

1. Place a spirit level on the top front edge of the cabinet with the door fully closed. Adjust the front legs only until the merchandiser is reasonably level.
2. Hold the door open about four inches.

WARNING

To help avoid personal injury, have an assistant hold the merchandiser while you adjust the leg levelers.

3. Adjust the back legs so that the back leg leveler on the hinge side is off the floor just enough so a piece of paper can slide under it with a bit of resistance.
4. For proper weight distribution on all four legs, raise the back leg on the hinge side by unscrewing the leveler 1 1/2 turns.

NOTE

You may need to use pliers or channel locks to loosen the leg levelers.

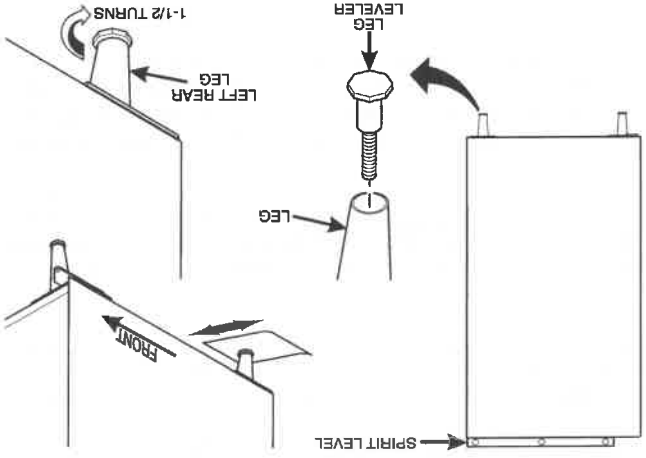



INSTALL THE DOOR LOCK (OPTIONAL)

The optional door locks available from National Vendors are listed below:

Flex-Ace (P/N 9992000)

- Corresponding key (P/N 9994000)

Van Lock (P/N 3112163)

- Corresponding key (P/N 3112164)
- Kit-lock and key (P/N 3112165)

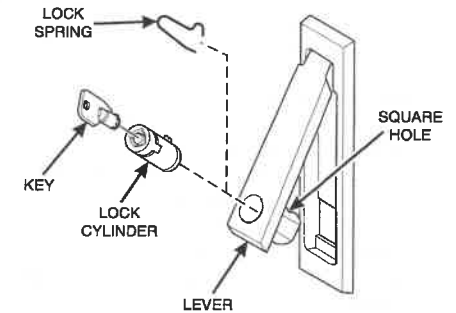

Proceed as follows:

1. Remove the lock spring.
2. Depress the lock pin and push the lock cylinder into the lever until the pin snaps into place.
3. Test lock the mechanism with the key.

HOME THE DRIVE SHAFT CHANNELS

The drive shaft channels must be in a horizontal position before the trays can be installed. If they are not, perform the following steps:

1. Open the monetary compartment. If the merchandiser is equipped with the optional door lock, the key will be in the coin return receptacle.
2. Set the MAIN SWITCH to the ON position. The tray motor should run, moving the drive shaft couplings to the horizontal position.

WARNING

If it is necessary to check the merchandiser with power ON and the door or monetary compartment interlock switch either depressed or pulled out, keep clear of the elevator and wiring to avoid possible injury or electrical shock.

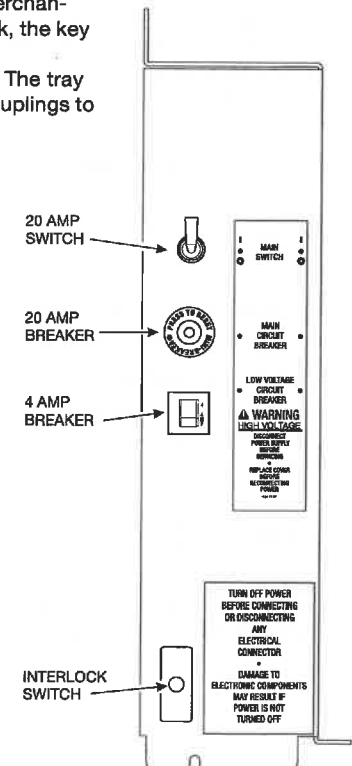
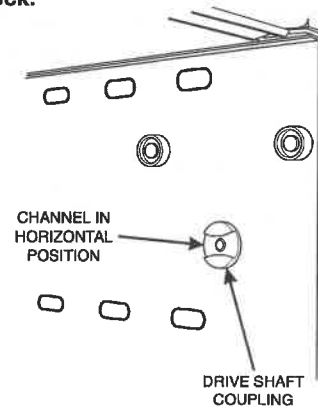



INSTALL THE COIN MECHANISM

CAUTION

Set the main power switch to OFF before installing the coin mechanism.

1. Refer to the instructions provided with the coin mechanism and remove the coin validator assembly.

2. Loosen the coin mechanism mounting screws on the merchandiser to stand

off about 1/8" (0.3 cm).

3. Place the coin mechanism in location with key holes over the three mounting screws.

4. Tighten the mounting screws and reinstall the coin validator assembly.



5. Connect the coin mechanism power input plug with the power supply connector in the merchandiser.

6. Route the coin mechanism harness under the cable clamp and tighten screws.

7. If your coin mechanism is a MARS 6000 or TRC 6010 XV, set the high quarter switch as shown, then continue. If your coin mech is another model, disregard this step.

8. Continue.

9. If not already plugged in, plug the power cord into the electric outlet and turn the main power switch ON.

9. Press , and press  once. Press

 until either **DUNB MECH** or **MDB MECH** is displayed (depending upon which coin mech type you have).

10. If you chose **MDB MECH** in the previous step, skip to step 10 and perform the rest of this procedure. If you chose **DUNB MECH** in the previous step, fill the coin tubes with coins. Make sure the coins are not shingled. You are now finished setting up your coin mech. Do not perform the rest of this procedure.

11. Press  until the standby message is displayed, then press .

12. Insert at least 20 coins of each denomination through the coin chute. Continue to fill the coin tubes either through the coin chute or the tops of the tubes.

13. Visually check the coin tubes to make sure coins are not shingled.

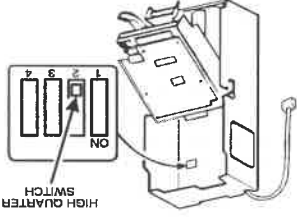
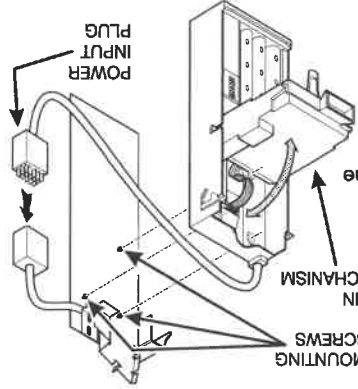



14. Press 

15. If credit is still shown in the display, turn the machine power OFF, then back ON.

OPEN TRAY INTERLOCKS

Four tray interlocks are located on the left wall of the food compartment; one interlock for each food tray. These interlocks are designed to assure that the food trays are fully pushed into the food compartment for proper merchandiser operation. They are also designed to prevent accidental breakage of the display door glass.

When a food tray is pulled partially or all the way out of the food compartment, the tray interlock cam for that tray is flipped to the open position, thereby locking the display door in the open position. The display door must be fully opened before the tray interlock cams can be flipped to the open position.

All tray interlock cams are factory set in the locked position. Before a food tray can be inserted, the tray interlock cam for that tray must be in the open position. Use a screwdriver to flip each of the four tray interlock cams to the open position.

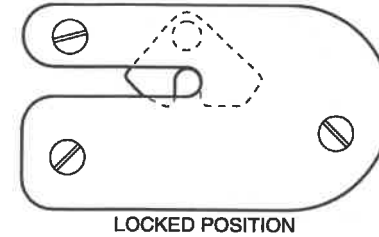

LOCKED POSITION

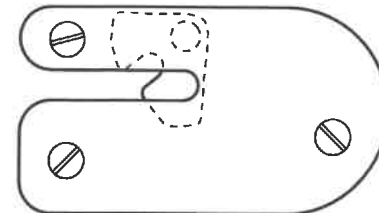

OPEN POSITION



INSTALL TRAYS

Check to see that the drive shaft coupling bar on the right side of the food tray is locked in the horizontal position.

WARNING
The food tray assemblies weigh approximately 60 lbs. (27.4 kg). **DO NOT** attempt to install or remove a food tray without assistance.

Lift the food tray assembly to a horizontal position so that the left and right slide channels are aligned with the rollers on the food compartment walls. Slide the tray into the merchandiser until it stops.

NOTE
For loading convenience, the tilt-pullout adjustment to the tray may be made (see **ADJUSTMENT AND REMOVAL PROCEDURES**, section 3).

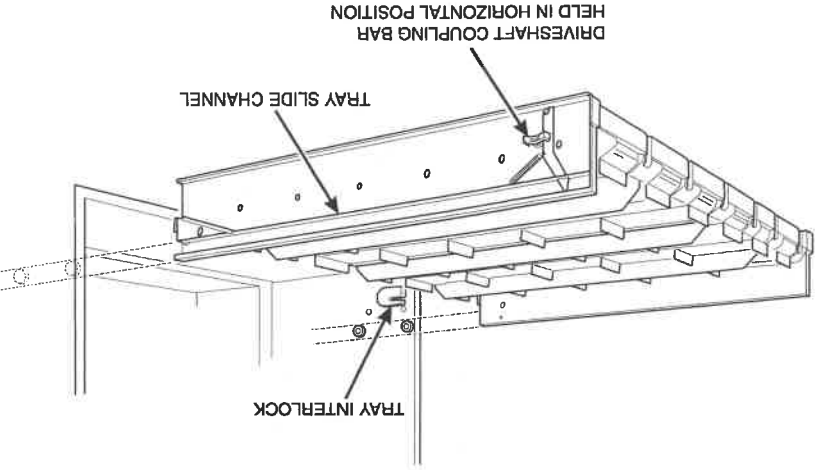



INSTALL THE HATCH SHELL

1. Locate the locking rod within the cabinet hatch channels on the back of the merchandiser. Remove tape and pull out the rod.
2. Attach the hatch shell by inserting the shell fingers over the rod at the top of the cabinet.

WARNING

The hatch shell weighs approximately 80 lbs. (36.3 kg.), requiring two people for installation.

3. Swing the shell down so the shell channels fit flush between the cabinet hatch channels.
4. Insert the straight end of the locking rod into the shell and cabinet channels until the bent end of the rod is in line with the oblong hole.
5. Remove the nut from the locking rod and rotate the rod inside the cabinet.
6. Open the monetary compartment and securely reattach the nut.
7. Check to see that the shell is sealed tightly to the cabinet.

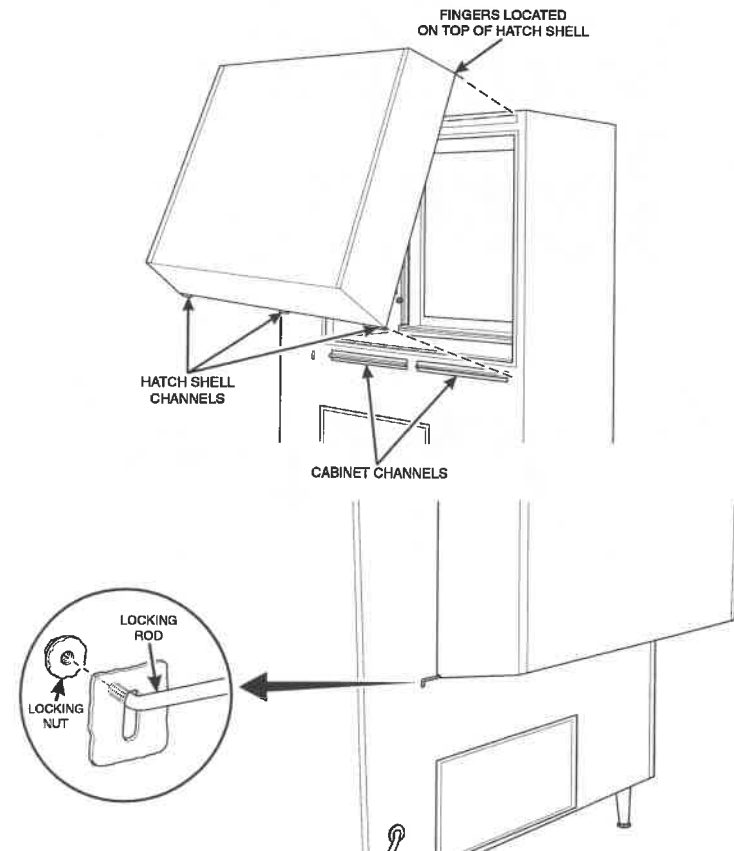



PREPARE THE MERCHANDISER FOR VENDING

This part contains step-by-step instructions for getting your merchandiser ready to work. For best results, familiarize yourself with the sequence of steps and read the instructions for each job. Refer to the figure below to help you identify the major components of your merchandiser.

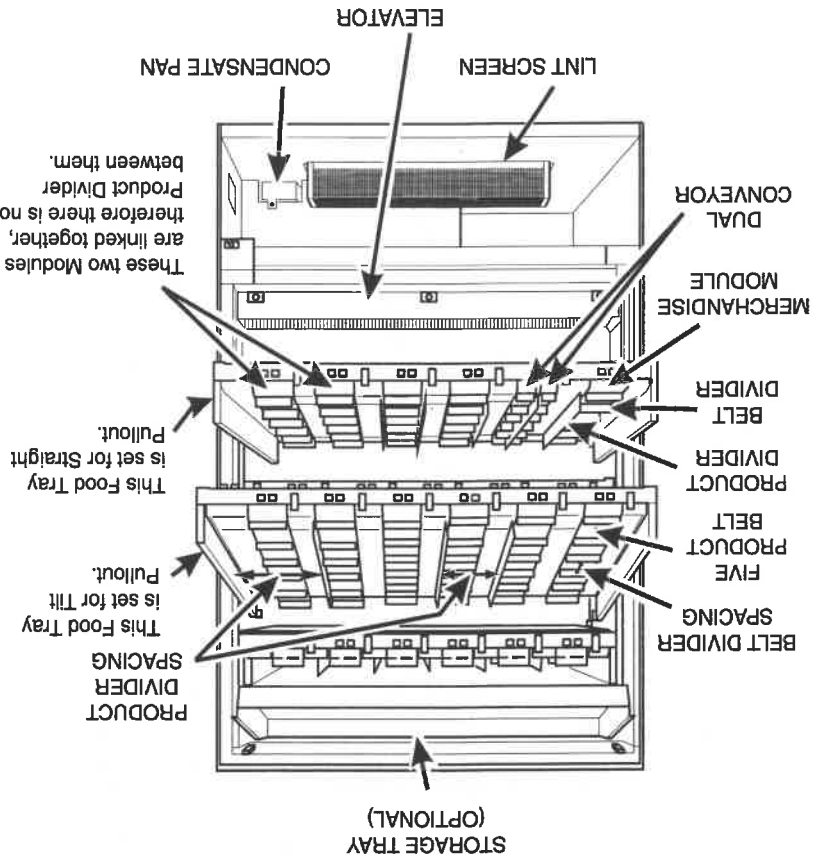



1. Set Up the Bill Validator

Follow the steps given in "SELECT BILL VALIDATOR AND OPTIONS", section 2.

2. Install Selection and Price Labels

A variety of selection and price labels are packaged in a plastic bag that is located in the monetary compartment.

Insert the appropriate labels into the slots in front of each belt as shown.

When modules are coupled together to vend one product, insert the selection and price labels in the left hand module slots. Insert blank labels in the right hand module slots.

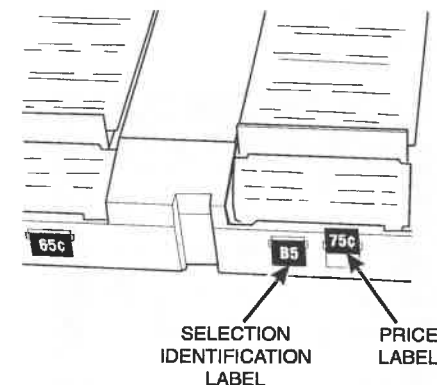

3. Set Prices

Follow the steps given in "SET PRICES", section 2.

4. Set the Time

Follow the steps given in "SET THE TIME OF DAY", "SET THE DAY OF THE WEEK", and "SET MONTH, DAY, AND YEAR", section 2.

5. Adjust Trays to Fit the Product to be Loaded

Follow the steps given in "ADJUSTING PRODUCT DIVIDERS" and "COUPLING TWO MODULES TO VEND TOGETHER", section 3.

NOTE

Do not load products until the machine temperature is 45° F (7° C) or less.

6. Load Product in the Merchandiser

7. Perform Test Vends to Verify Proper Operation

Follow the steps given in "TEST VEND SELECTIONS AND VERIFY CREDIT ADDED", section 2.

SECTION II. PROGRAMMING

Some setup, test, and maintenance operations are computer controlled. The control panel switches (see figure 1) and the selection panel switches (see figure 2) regulate these operations.

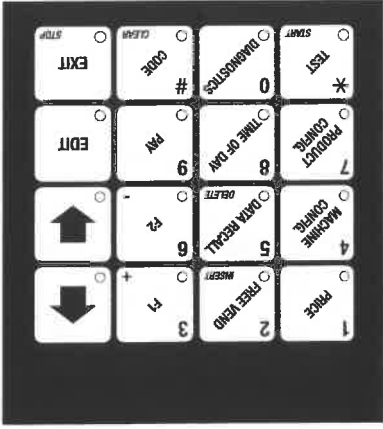

Figure 1. Control Panel



Figure 2. Selection Panel





The Displays

The 10-character display performs two functions, and is referred to in this book as "the display":

1. It shows the customer's selection and how much credit is in the machine, as well as the ready, service, and time of day messages.
2. It provides information and feedback to the service person during maintenance.



The Function Keys

The keys on the control panel can be used for up to three things:

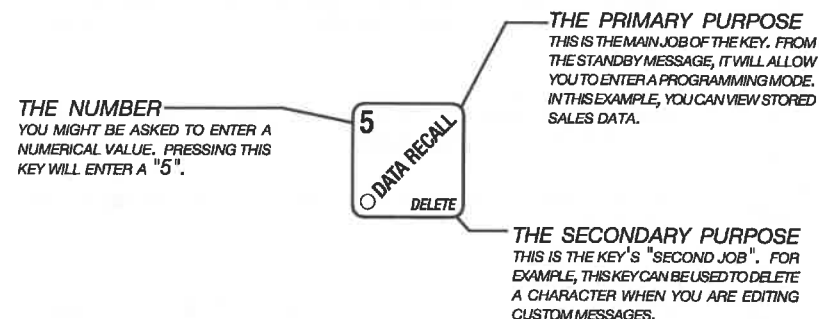

Other Keys

The MOVEMENT keys on the control panel let you move inside a mode, and back and forth between modes. To see how these keys let you move around, study the flow diagram on the next page.



The up and down arrow keys are your "legs", which let you move up and down the list of tasks. These keys are what let you continue from one step to the next in programming procedures.



This is your "activate" or "choose" key. It "opens a door" to additional information and lets you begin a programming task once you are inside of a mode. Sometimes, it is used as a toggle switch to show you your choices during a programming task.



This is your "end" key. Pressing it one or more times will move you back to the start of the mode, or all the way back to the standby message.



Control Panel Switch Functions Explained

Each of the control panel switches has one or more jobs to do. This list will give you a short overview of those jobs.

Press this button to put your machine into the Price Setting mode. You can see maximum and minimum machine prices, and change prices for entire machine, entire tray, or individual selection. This also allows you to lock out tray selections if two belts are coupled together.



Press this button to select the Free Vend mode.



Press this button to view the machine temperature and the software version number.



Press this button to:
• Select display language
• Select coin mechanism and options
• Select bill validator and options
• Select winner feature



Press this button to view total sales and vends by whole machine, tray, or selection. Clear resettable data. Displays various machine data; health control settings, power failure time and duration information, and machine ID.



Press this button to:
• Download data into your portable data collection device (PDCD), OR
• Set printer baud rate, depending upon which device you are using



Press this button to set the internal machine temperature (supervisor mode only)



Press this button to:
• Set time of day
• Set day, month, year
• Set up time of day intervals for inhibit, frevend, and discount vending
• Select display messages
• Edit messages



Press this button to pay one or more coins from the coin mechanism.



Press this button to see any fault or condition that may place the machine out of service



Press this button to:
• Perform TEST VENDS
• Test machine functions



Press this button to:
• Enter the SUPERVISOR mode
• Change the SUPERVISOR access code
• Lock and unlock access to functions
• Set printer or DEX options



Control Panel Switch Functions Explained



Programming Flow Charts

After you become familiar with the programming functions, you will be able to perform them without using the detailed, step-by-step tables. The following group of flow charts will give you a quick reference to the functions each key performs. If you need additional information, just refer to the page shown in the chart.

Machine Configuration Functions

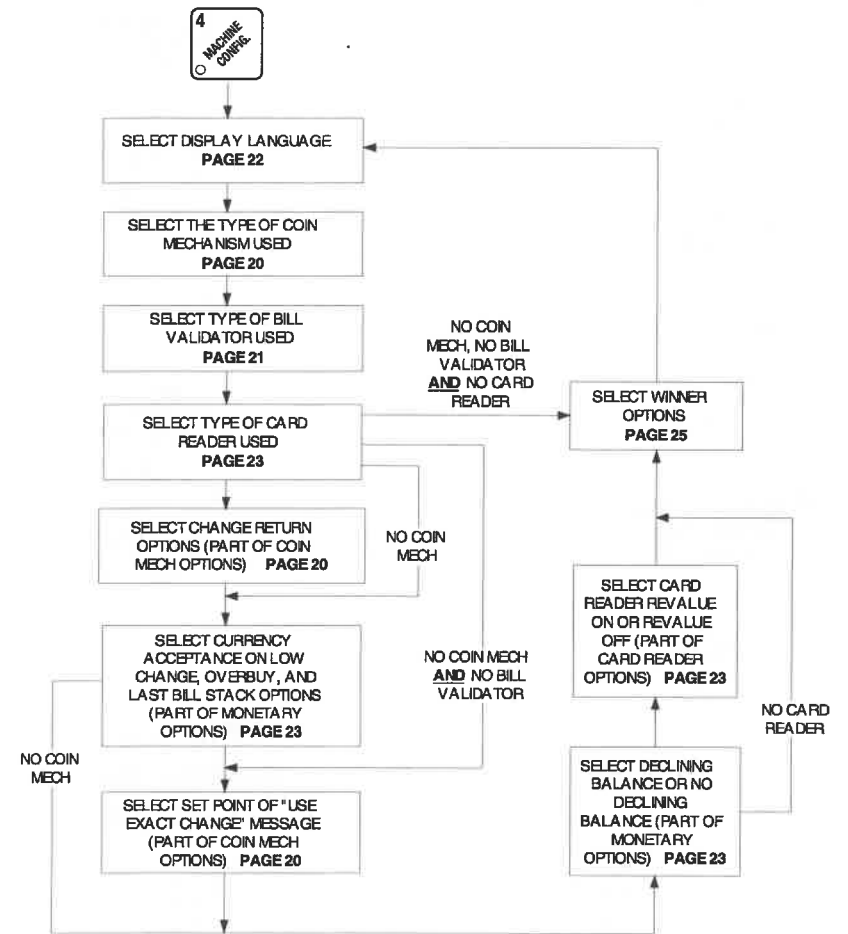



Pricing



Time of Day

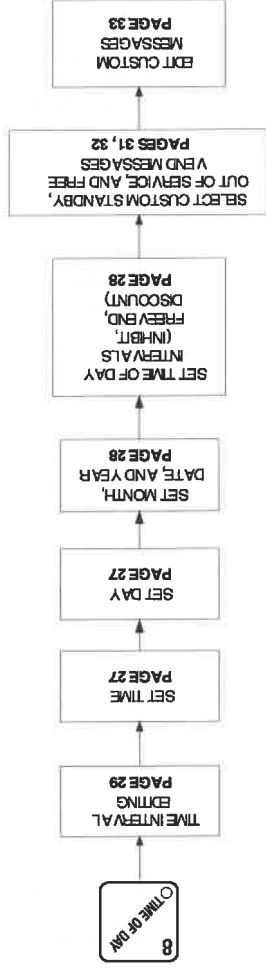

DEX/Printer

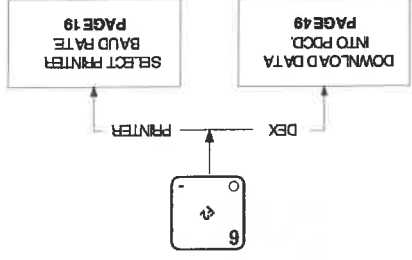

Product Configuration Functions



Supervisor Functions

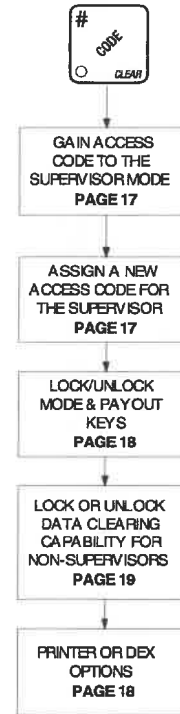

Misc.

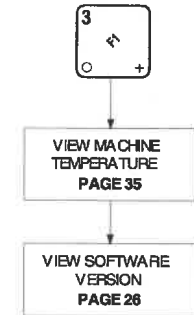

View Diagnostics

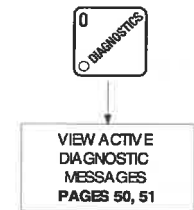

Free Vend

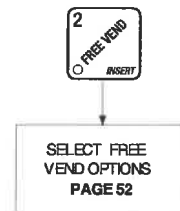

Payout Coins

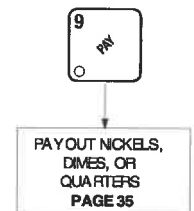



Tests

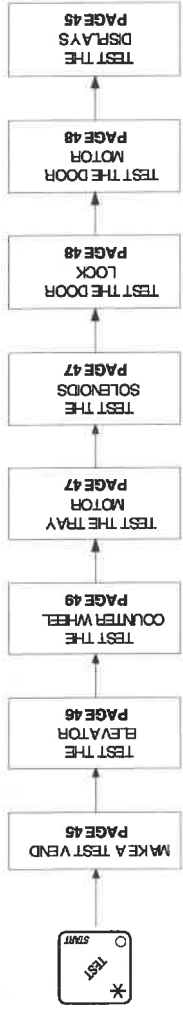

View and/or Clear Data

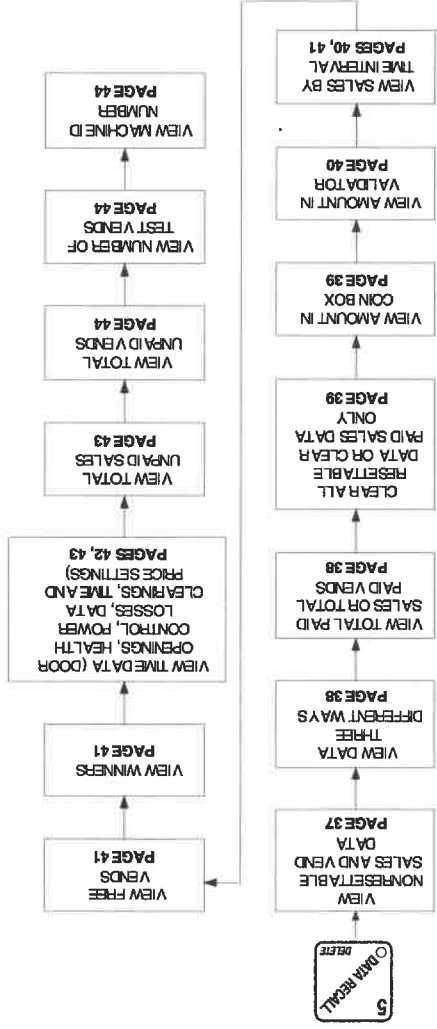





GAIN ACCESS TO THE SUPERVISOR MODE

1. Press . The display shows: *ENTER CODE*. You must enter the four-digit supervisor code within 6 seconds to gain access.

NOTE

A new machine has a factory-set supervisor code of 0000.

When you have entered the right code, you will hear two beeps and see *UNLOCKED* in the display. After a few moments, the standby message returns.

2. At the standby message, press , then . You are now ready to perform various supervisor functions.



ENTER A NEW SUPERVISOR CODE

1. Follow the steps in **GAIN ACCESS TO THE SUPERVISOR MODE**.
2. Press  until the display shows *SUPER XXXX*. The X's represent the current supervisor code. Use the number keys to enter a new code.

IMPORTANT!

If you enter a new code, be sure to keep a written record of it. There is no other way to access the SUPERVISOR mode.

3. Press  until you have left the function.



LOCK OR UNLOCK MODE OR PAYOUT KEYS



1. Follow the steps in **GAIN ACCESS TO THE SUPERVISOR MODE**.



2. Press **↑** until the display shows either **X LOCKED** or **X UN-**

LOCKED. "X" refers to the number or character shown on the mode or

payout key in question (1 through 9, # and *). To see if a key is locked or

unlocked, press that key.



3. Press **EDIT** to change between locked and unlocked. When anyone

other than the supervisor tries to enter a locked mode, the display shows

LOCKED.

NOTE

The following mode keys cannot be locked out:



4. Press **EXIT** until you have left the function.



SET PRINTER OR DEX OPTIONS



1. Follow the steps in **GAIN ACCESS TO THE SUPERVISOR MODE**.



2. Press **↑** until the display shows one of the following:

PRINTER means that data will be sent directly to a printer,

OR

DEX ONLY means that data remains in memory after it is downloaded into

a portable data collection device,

OR

DEX + CLR means that resettable data is cleared after it is downloaded

into a portable data collection device.





3. Press **EDIT** to switch between the three choices.



4. Press **EXIT** until you have left the function.



LOCK OR UNLOCK DATA CLEARING ACCESS

1. Follow the steps in **GAIN ACCESS TO THE SUPERVISOR MODE**.
2. Press  until the display shows either **#. LOCKED** or **#. UNLOCKED**. **LOCKED** means that non-supervisors cannot clear resettable machine sales and vend data from the  key.
3. Press  to switch between **#. LOCKED** and **#. UNLOCKED**.

NOTE

The supervisor can clear data regardless of this setting, provided the supervisor code was correctly entered first.



4. Press  until you have left the function.



SELECT PRINTER BAUD RATE (PRINTER MODE ONLY)

BAUD RATE



The speed of data transfer, expressed in bytes per second. Your printer can receive data at a certain rate, and you must tell the machine what that rate is.

1. Press . One of the following is displayed:
BAUD 1200, BAUD 2400, BAUD 4800, BAUD 9600
2. Press  until the correct baud rate for your printer is displayed.
3. Press  until you have left the function.



SELECT COIN MECHANISM AND OPTIONS



1. Press , then press  until the current COIN MECHANISM is shown in the display. Press  to choose the desired coin mechanism.

Your choices are: **DUWB MECH, MDB MECH, EXEC MECH, or NO MECH**

2. Press  until the display shows **CHANGE X.XX**.

Coins and bills which are less than or equal to this value will be returned without a purchase being made.
Examples:

CHANGE 0.00 - Forced vend; NO change returned without a purchase.
CHANGE .25 - Nickels, dimes, and quarters returned without purchase.

CHANGE 1.00 - \$1 bills and SBAs will be returned as change without purchase. Nickels, dimes, and quarters are also returned.

3. Press  until the display shows: **LOW.M56 X.XX**. The display will

show **USE EXACT CHANGE** when the amount of available change in the coin mechanism falls below the value of "X.XX". Enter a value with the number keys. For example, if **LOW.M56 1.00** is displayed, the **USE EXACT CHANGE** message is displayed when less than a dollar's worth of change is in the coin mechanism.

4. Press  until you have left the function.



SELECT BILL VALIDATOR AND OPTIONS

1. Press , then press  until one of the following is displayed:

NO DBV - No bills will be accepted or there is no bill validator installed (you can exit the function).

SER.1.2.5.10.20 - The serial bill validator is selected and will accept \$1, \$2, \$5, \$10, and \$20 bills. Use BILL SELECTION METHOD below to change the bills which will be accepted.

MDB.1.2.5.10.20 - A standard MDB bill validator is selected. It will accept \$1, \$2, \$5, \$10 and \$20 bills. Use BILL SELECTION METHOD below to change the bills which will be accepted.

BILL SELECTION METHOD:

The standard \$1, \$2, \$5, \$10 and \$20 bills are enabled by pressing the 1, 2, 5, 6, or 7 key(s), respectively, to display which bill(s) will be accepted.

MDB. <*> - An MDB bill validator which accepts non-standard bills or tokens is connected and operating. Press



to enter list of bills. (See **INITIAL SETUP**

OF NON-STANDARD BILL VALIDATOR on the following page.)

BILL LIST OPERATION:

Use  and  to scroll through the list of bills.

Use  to turn the bill acceptance ON or OFF.

Use  to move up to the top level screen.

1. 1.00 ON - 1. = Bill validator channel 1, each bill has its own channel
1.00 = Bill value
ON = \$1.00 bill will be accepted



1. 1.00 OFF - OFF = \$1.00 bill will not be

accepted

TRN - Token bills (same as coupon bills)

INITIAL SETUP OF NON-STANDARD BILL

VALIDATOR:

Connect the bill validator, select MDB in the bill

validator selection screens. The standard

"MDB.1.2.5.10.20" screen will appear first. Exit

the bill validator setup by pressing . Bill

information is now collected from the validator. Re-enter the bill validator selection screen and the non-standard screen "MDB.<*>" will appear.

- The pulse bill validator will accept \$1 bills.



Press  to choose the desired option.



2. Press  until you have left the function.

SELECT DISPLAY LANGUAGE



1. Press . The current LANGUAGE is shown in the display. Press



 to choose the desired language. Your choices are: **ENGLISH,**

DEUTSCH, FRANCAIS, ESPANOL, PORTUGUES, SWEDISH, or



NEDERLANDS.



2. Press  until you have left the function.





SELECT CARD READER AND OPTIONS

1. Press , then press  until the current card reader is shown in the display. Press  to choose the desired card reader. Your choices are: *NO CARD*, *DUMB CARD*, or *MDB CARD*.

NOTE

If you selected *NO CARD* you can exit the function.

2. Press  until one of the following is displayed:
REVALUE.ON - Allows credit to be transferred onto the card
REVALUE.OFF - Credit cannot be transferred to the card

Press  to display the desired choice.

3. Press  until you have left the function.





SELECT MONETARY OPTIONS

This function lets you:

- Set declining balance,
- Set currency acceptance on low change,
- Set overbuy options,
- Set last bill stacking options

DECLINING BALANCE *Once credit is established, multiple vends may occur until the coin return is pressed.*

1. Press , then press  until one of the following is displayed:
DECLINE.ON - More than one vend is allowed, with a declining balance.
OR
DECLINE.OFF - A declining balance is not allowed.

Press  to display the desired choice.



2. Press  until one of the following is displayed:

RCC <\$\$X.XX - The last bill which meets or exceeds maximum price will be held in escrow.

OR

RCC5TRX.XX - The last bill which meets or exceeds maximum price and MDB coupon bills (token bills) will be immediately

stacked.

Example: If setting is **RCC5TR1.00** and maximum price is \$1.50, this setting will immediately stack the second \$1.00 bill inserted.

Press  to display the desired choice.

The value of "X.XX" has two purposes:

a. The value of "X.XX" tells the machine how big a bill or coin to accept even though there is not enough change in the coin mech to cover all possible paybacks.

• For example, enter **1.00**. Therefore, the machine will take a dollar bill or coin even though there is less than \$1.00's worth of change. Entering **5.00** tells the machine to take a five even though there is less than \$5.00's worth of change, and so forth.

NOTE: This could cause a customer to be short-changed.

• Entering **0.00** means that bills or coins will only be accepted if there is enough change to cover them.

b. The value of "X.XX" tells the machine how much the customer is allowed to overbuy a product. The customer will be short-changed when an overbuy occurs.

Example:

For a value of \$0.25: if there is no change in the machine and the customer inserts a \$1.00 bill. The customer can purchase a product for \$0.75 even though the change cannot be paid back. The customer will be short-changed. Normally a purchase will not be approved unless all change can be paid.

Entering 0.00 means that the vend will only be approved when the correct change can be returned (overbuy disabled).

3. Press  until you have left the function.



SET UP WINNER MODE

WINNER

At preselected intervals, a customer may receive a refund for a selection. You can select the interval and qualifying selections.

1. Press , then press  until one of the following is displayed:

WINNER OFF Winner function is disabled.

OR

WIN XXX Winners are allowed at certain intervals, represented by "XXX".



Press  to display the desired choice.

If you selected **WINNER OFF**, you can exit the function.

2. The display shows **WIN XXX**. XXX represents the number of vends which must occur per each winner vend. For example, an interval number of 50 means that a winner can happen any one time during the next 50 vends. Using the number keys, enter an interval number between 10 and 9999.



3. Press . The display shows * . - - - -. The dashes in the display represent which trays are allowed winners. Press the appropriate letter key to enable a tray, press the key again to disable it. For example, pressing A, C, and D will cause the display to look like this: **A - C D**, meaning that all A, C, and D selections can have a winner.

ADVANCED OPTIONS:

- Press  to enable all trays.
- Press  to deactivate all trays.
- Press 1 - 6 to set winner by selection.



AN EXAMPLE . . . You want to enable winners on all trays except A. Do the following:



- a. Press . The letters **H** through **D** appear in the display instead of the dashes.
 - b. Press "A". The letter **H** in the display is replaced by a dash.
4. Press  until you have left the function.

SET TEMPERATURE (SUPERVISOR MODE ONLY)

1. Press . The display shows +/- **+38°F**. This means that **38°F** is the current temperature setting.

OPTION:

Press  at this point to display the temperature in the standby message.



2. Press  to raise the setting; press  to lower the setting. The range of values is between 35°F and 41°F.

3. Press  to choose between display in °F or °C.

4. Press  to enable the cabinet temperature to display with the standby message.

5. Press  until you have left the function.

VIEW SOFTWARE VERSION

1. Press , and press  until the display shows **VER XXXXXX**. "XXXXXX" represents the current software version number.

2. Press  until you have left the function.



SET THE TIME OF DAY

1. Press . The display shows *TIME HH.MM*. "HH.MM" is the time of day in 24-hour format.
2. Enter the current time using the number keys.





NOTE

9:00 am is entered with a leading zero, like this: 0900; 9:00 pm is entered as 2100.

3. Press  until you have left the function.





SET THE DAY OF THE WEEK

1. Press , and press  until the display shows @ SATWTFS. The letter representing the currently set day of the week will be flashing.
2. Press  until the correct day of the week is flashing.
3. Press  until you have left the function.





SET MONTH, DAY, AND YEAR



1. Press , and press , until the display shows **MM/DD YY**.
2. Enter the current month, date, and year using the number keys.

For example, press the following keys to enter February 22, 1998:

0, 2, 2, 2, 9, 8

3. Press  to switch between MM/DD and DD-MM (European date format) display.
4. Press  until you have left the function.

SET TIME-OF-DAY INHIBITED VENDING



Vending can be inhibited up to four times a day.

1. Press , then press , until the display shows **INHIB**.

2. Go to the TIME INTERVAL EDITING procedure for an example of how to set up time-of-day inhibited vending.

SET TIME-OF-DAY FREE VENDING



Vending can be free up to four times a day.

1. Press , then press , until the display shows **FREEV**.

2. Go to the TIME INTERVAL EDITING procedure for an example of how to set up time-of-day free vending.

SET TIME-OF-DAY DISCOUNT VENDING



Vending can be discounted up to four times a day. For example, this can be used to favor early-arriving employees.

1. Press , then press , until the display shows **DISCT**.

2. Go to the TIME INTERVAL EDITING procedure for an example of how to set up time-of-day discount vending.



TIME INTERVAL EDITING

You can select up to four times of day for each special vending period.

NOTE

If two or more of these time periods overlap, the interval with the highest priority will overrule the other(s). This order of precedence is:

1. INHIBIT
2. FREEVEND
3. DISCOUNT

For example, if a DISCOUNT time period is scheduled for a certain area before the end of an INHIBIT time period, DISCOUNT does not begin until the INHIBIT interval has ended for that area.

The time interval editing procedure is almost the same for the INHIBIT, FREEVEND, and DISCOUNT intervals. There is one difference for the DISCOUNT time interval, so we will use it in our example. Assume you just finished the SET TIME-OF-DAY DISCOUNT VENDING procedure. Step 1 picks up where you left off . . .

1. The display shows *DISCT - - - -*. Press the number of the time interval

you want to edit, or  to edit time interval 1 (we'll use interval 1 for this example).

2. The display shows *1.DISCT ON* or *1.DISCT OFF*. This display tells you

whether your time interval (represented by 1) is on or off. Press  to change the condition of the time interval.

NOTE

If you turn an interval ON, it must be edited. You can edit a time interval now, then turn it OFF until another time.

3. Press . The display shows *1.DSCT X*. "X" represents the discount percentage for this period. Enter a discount percentage of 25 with the number keys. (Discount percentages of from 0 to 99 are permitted.) The machine will apply a 25% discount to each price, rounding up to the nearest nickel (or whatever is the smallest coin accepted by the coin mechanism).



4. Press . The display shows **15TRT X.XX**. "X.XX" is the currently set start time. Enter a new start time (24-hour format) for this interval. To enter the time for 3:30 pm, enter 1530.

5. Press . The display shows **15TOP X.XX**. "X.XX" is the currently set stop time. Enter a new stop time (24-hour format) for this interval. To enter the time for 6:00 pm, enter 1800. You have now established a 25% discount that starts at 3:30 pm and ends at 6:00 pm.

6. Press . The display shows **1@-----**. The dashes represent the days that this time interval is active. Pressing number keys 1 through 7 switches the days on/off. For example, press "2", "4", and "6". The display now shows **1@-W-U-F-**. This discount interval is only active on Monday, Wednesday, and Friday.



7. Press . The display shows ***-----**. The dashes represent the trays affected by this time interval. Press the appropriate letter key to enable a tray, press the key again to disable it. For example, pressing A, C, and D will cause the display to look like this: **A-C-D**, meaning that all A, C, and D selections are affected by this interval.

Advanced:

- Press  to enable all levels.

- Press  to disable all levels.

- Press **1 - 6** to set time interval by selection.

8. Press . The display shows **1.MESG OFF** or **1.MESG X**. "OFF" means there is no custom message selected, and "X" represents the custom message number set for this interval. Press the number key of the message (1 through 8) you want displayed. To edit this message, press  and follow the procedure given in **EDIT CUSTOM MES-**





SAGES. Press **0** to turn the message OFF for this time interval.

9. Press  until you have left the function.







STANDBY MESSAGE: The message that is displayed during normal vending periods when there are no out-of-service faults on the machine.

SELECT A STANDBY MESSAGE

1. Press , then press  until the display shows **STANDBY XX**.
"XX" represents the current message number selected for the standby message. Two dashes mean that the factory-set message is selected.
2. To select a message, just press the corresponding number (1 through 8). To display the factory-set message, press 0.
3. The selected message (except the factory-set message) can be edited.
To do this, press  and follow the procedure given in **EDIT CUSTOM MESSAGES**.
4. Press  until you have left the function.

SELECT AN OUT-OF-SERVICE MESSAGE

1. Press , then press  until the display shows **SERVICE XX**.
"XX" represents the current message number selected to display when the machine is out-of-service. Two dashes mean that the factory-set message is selected.
2. To select a message, just press the corresponding number (1 through 8). To display the factory-set message, press 0.
3. The selected message (except the factory-set message) can be edited.
To do this, press  and follow the procedure given in **EDIT CUSTOM MESSAGES**.
4. Press  until you have left the function.



SELECT A FREEVEND MESSAGE

1. Press , then press  until the display shows **FREEVEND**

XX. "XX" represents the current message number selected for the message that displays when the machine is in the frevend mode. Two dashes mean that the factory-set message is selected.

2. To select a message, just press the corresponding number (1 through 8). To display the factory-set message, press **0**.

3. The selected message (except the factory-set message) can be edited.

To do this, press  and follow the procedure given in **EDIT CUS-**

TOM MESSAGES.

4. Press  until you have left the function.



EDIT CUSTOM MESSAGES

1. Press , and press  until the display shows *EDIT MSG X*.

Press the number of the message you want to edit. (X represents the message number you pressed).

2. Press . The message text is displayed with the first character flashing.

3. To view the message, press . The message scrolls across the

display. To stop the scrolling, press .

4. When the character you want to change is flashing, either enter it directly,

or use  and  to step through the character set until the

desired character is displayed. Use the arrow keys to highlight different characters. See the section on the next page for an explanation of special keys and the character set.

SHORTCUT

Instead of stepping through the whole character set to enter a letter that is not on your keypad, enter one close to the one you want, then step to it. Example: If you want to enter an L, first

press , then press  six times. Your L should now be displayed.

THE END OF MESSAGE CHARACTER

This is the most important character in your message, because it tells the machine when the message is ended. If you don't use this character, your message will be followed by a bunch of zeros. This character can be selected either from the character set or by a direct key entry (see the next page).





ENTERING YOUR MESSAGE

Most of the keys on the control panel have a special purpose to help you create and edit your messages:

- 1 Inserts an **R** at the flashing character.
- 2 Inserts a space at the flashing character.
- 3 Inserts an **S** at the flashing character.
- 4 Inserts an **S** at the flashing character.
- 5 Deletes the current character and closes up the space.
- 6 Deletes the current character and leaves the space.
- 7 Inserts a **T** at the flashing character.
- 8 Repeats the letter to the left of the flashing character.
- 9 Repeats the letter to the left of the flashing character.
- 0 "Pages" through the message, ten characters (one screen) at a time.
- 1 Steps forward and backward through the message, one character at a time.
- 2 Steps forward and backward through the message, one character at a time.
- 3 Steps forward and backward through the character list, one character at a time.
- 4 Steps forward and backward through the character list, one character at a time.

THE CHARACTER SET

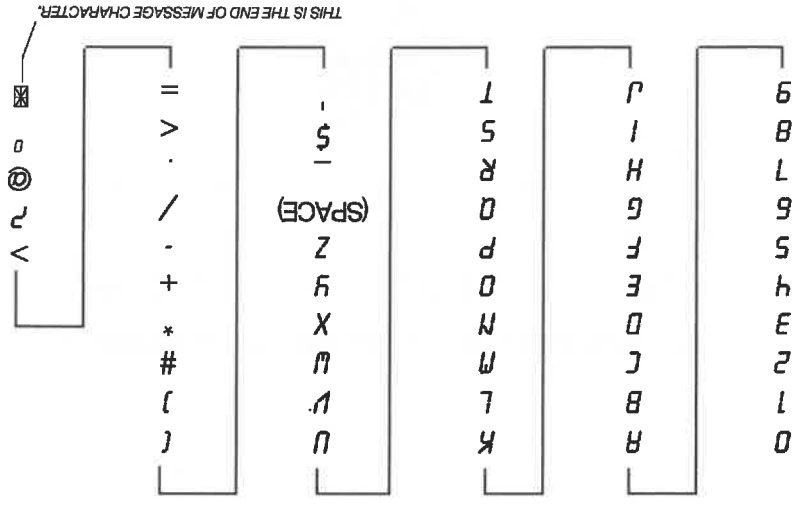



VIEW MACHINE TEMPERATURE

1. Press . The display shows *TEMP 38° F*. (This example shows that the temperature is 38 degrees Farenheit.)

NOTE

If the cold door has been opened recently, the above display will include a numerical value indicating how many minutes remain in the health control grace period. For example, the display *19.H +73° F* means that 19 minutes remain in the health control, and that the current temperature inside the machine is 73° Fahrenheit.

2. To change the display units, press . The display now shows *TEMP 23° C*.

- An apostrophe (') preceding the **F** or **C** means a sensor error exists and the displayed temperature is invalid. A decimal point following the **F** or **C** means the compressor is running.

NOTE





When the monetary door is closed, you can view the

temperature by pressing  on the selection panel.

3. Press  until you have left the function.



PAYOUT COINS (coin mech. equipped units only)

1. Press . The display shows *NDQ =123*.
2. Press  to pay out one *Nickel*.
3. Press  to pay out one *Dime*.
4. Press  to pay out one *Quarter*.
5. To continuously pay out coins, hold down the appropriate key.
6. Press  until you have left the function.



SET PRICES; VIEW MAXIMUM/MINIMUM PRICES

1. Press . The display shows **** 2.50 .25**. This display shows the maximum and minimum prices set in the machine. In this example, the maximum price is \$2.50 and the minimum is \$0.25.

2. Enter prices as using one of the following methods:

SET ENTIRE MACHINE TO ONE PRICE . . .

a. Press . The display shows **** X.XX**. X.XX is the current price (if one is set). If no entire machine price is set, there are no Xs present. Enter a price using the number keys. All selections in the machine are now set to this price.

SET ALL SELECTIONS ON A TRAY TO ONE PRICE . . .

a. Press the letter key (A - D) corresponding to the tray you want to price. The display shows **B* X.XX .YY**. This display shows the maximum (X.XX) and minimum (.YY) prices set for the B tray.

b. Press . The display shows **B* X.XX**. Enter a price using the number keys. All selections on this tray are now set to this price.

SET THE PRICE OF AN INDIVIDUAL SELECTION:

a. Press the number of the selection to be priced. (Example: B1.) The display shows **B1 X.XX**. Enter a price using the number keys. The selection is now priced.

b. Press another letter key, or  to price another selection.

SET ALL SELECTIONS IN A COLUMN TO ONE PRICE:

a. Press **1 - 6**. The display shows ***Z .XX.YY**. XX and YY are the maximum and minimum prices for this column.

b. Press . Enter a price using the number keys.

c. Press , or  to price another selection.

**BLOCK OR UNBLOCK SELECTIONS**

Two belts can be physically coupled together to vend longer products (see Section III - Adjustment and Removal Procedures). After doing this, **you must block the selection on the right** to prevent customers from losing money. In the following example, you have coupled the belts for selections **A1** and **A2**:

1. Press , then press **A2**. The display shows **A2 X.XX**. This display shows the price currently set for the A2 selection (X.XX).
2. Press . The display now shows **A2 - X.XX**. The minus sign (-) means that A2 is now blocked, and if a customer tries to vend it, the **MAKE ANOTHER SELECTION** message is displayed.

NOTE

As previously stated, the rightmost of any two coupled selections must be blocked.

3. To unblock a selection, press the appropriate keys, then press .
4. Press until you have left the function.

**VIEW NONRESETTABLE SALES AND VEND DATA**



1. Press . The display shows **NR\$ XX.XX**. "XX.XX" is a dollar and cents figure showing the total of all sales in the machine. This is a running total, and is not resettable.
2. Press . The display shows **NR X**. "X" is the total number of vends made by the machine. This is a running total, and is not resettable.
3. Press until you have left the function.





VIEW DATA THREE DIFFERENT WAYS





Paid sales and vends can be viewed three different ways: By whole machine, by tray, and by individual selection. The first screen of the data item shows its machine total. Once you have pressed :

- To view the data by tray, press the letter of the tray you want to see. You can then press  and  to see data for all the active trays.

- To view the data by individual selection, press the letter and number of the selection you want to see. You can then press  and  to see data for all the active selections.



VIEW TOTAL PAID SALES



1. Press , then press  until the display shows ****\$ XX.XX**. "XX.XX" is a dollar and cents figure showing the total of all **PAID** sales in the machine (as opposed to unpaid sales like winner and free vends). This is the total since the last time it was cleared.
2. If desired, view this data by tray and individual selection.
3. Press  until you have left the function.



VIEW TOTAL PAID VENDS



1. Press , then press  until the display shows **** XX.XX**. "XX.XX" is the total number of paid vends for the entire machine.
2. If desired, view this data by tray and individual selection.
3. Press  until you have left the function.







CLEAR ALL RESETTABLE DATA

1. Press . The display shows **NR\$ XX.XX**. This is a running total, and is not resettable.
2. Press and hold . Two beeps sound and the display shows **CLEARING** momentarily, and then changes to **FINISHED**. All data is cleared.
3. Press  until you have left the function.





CLEAR PAID SALES DATA ONLY

1. Press , then press  until the display shows ****\$ XX.XX**. "XX.XX" is a dollar and cents figure showing the total of all **PAID** sales in the machine (as opposed to unpaid sales like winner and free vends). This is the total since the last time it was cleared.
2. Press and hold . Two beeps sound and the display shows **CLEARING** momentarily, and then changes to **FINISHED**. All paid sales data is cleared; other data is not cleared.
3. Press  until you have left the function.



VIEW AMOUNT IN COIN BOX (NOT SHOWN IF ZERO)

1. Press , then press  until the display shows **CBX XX.XX**. "XX.XX" is the dollar and cents amount in the coin box.
2. Press  until you have left the function.





VIEW AMOUNT IN VALIDATOR (NOT SHOWN IF ZERO)



1. Press  then press  until the display shows *DBV XX.XX*

"XX.XX" is the dollar amount in the bill stacker.

2. Press  to show the quantities of bills in the stacker. For example, the display shows *\$01 20*, meaning that there are 20 dollar bills in the bill

stacker. Press  again to show the quantities of other bills, such as

\$5s, \$10s, or \$20s, or coupons (*TRN*).

3. Press  until you have left the function.

VIEW FREEEND SALES BY TIME INTERVAL (NOT SHOWN IF ZERO)



1. Press  then press  until the display shows *_0\$ XX.XX*

2. Press  then press  until the display shows *1.FRV .00*





This is the total sales for freeend interval 1, not shown if zero.

3. Press  to view intervals 2 through 4.

4. Press  until you have left the function.







VIEW DISCOUNT SALES BY TIME INTERVAL

1. Press , then press  until the display shows ****\$ XX.XX**.
2. Press . The display shows **1.DSC .00**. This is the total sales for discount interval 1 (not shown if zero).
3. Press  to view intervals 2 through 4.
4. Press  until you have left the function.







VIEW FREE VENDS (NOT SHOWN IF ZERO)

1. Press , then press  until the display shows **_0\$ XX.XX**.
2. Press , then press  until the display shows **FRV XX.XX**.
"XX.XX" is the total machine-wide freevends, not shown if zero.
3. Press  until you have left the function.



VIEW WINNERS (NOT SHOWN IF ZERO)

1. Press , then press  until the display shows **_0\$ XX.XX**.
2. Press , then press  until the display shows **WIN XX.XX**.
"XX.XX" is the total machine-wide winners, not shown if zero.
3. Press  until you have left the function.



VIEW TIME DATA



1. Press , then press  until the display shows **TIME DATA**.

2. Press . The following message scrolls across the display:

MAIN.1 3M 08/08 23.01

This example shows the latest time the monetary door was open (1). It was open for 33 minutes (33 M), and was opened on August 8 (08/08) at 11:01 pm (23.01). Press  if applicable, similar displays will appear for intervals 2, 3, and 4 (the next three latest intervals). Otherwise, go to the next step.

3. Press . The following message scrolls across the display:

RUX.5 40M 08/08 23.08

This example shows the latest time the cold door was open (1). It was open for 40 minutes (40 M), and was opened on August 8 (08/08) at 11:08 pm (23.08). Press  if applicable, similar displays will appear for intervals 5, 7, and 8 (the next three latest intervals). Otherwise, go to the next step.

4. Press . The following message scrolls across the display:

HC.ERR+69°F 08/08 23.01

The display shows the last time and date the health control was set, as well as the maximum temperature reached. This example shows that the health control was last set on August 8 at 11:01 pm, at a maximum temperature of 69° F.

NOTE

The temperature display units will be in °C if you selected Celsius during the temperature display function.

5. Press . The following message scrolls across the display:

LAST POWER 01/30 13.51 FOR 00.0.23

This example shows that the last time the machine lost power was on January 30 (01/30) at 1:51pm (13.51) for zero days, zero hours, and 23 minutes (00.0.23).



6. Press . The following message scrolls across the display:

LONGST POWER 01/30 10.58 FOR 00. 2.47

This example shows that the longest time the machine was without power was on January 30 (01/30) at 10:58am (10.58) for zero days, 2 hours and 47 minutes (00. 2.47).

7. Press . The following message scrolls across the display:

FULLCLEAR 01/30 8.58

This example shows that the last time resettable sales was fully cleared was on January 30 (01/30) at 8:58am (8.58).

8. Press . The following message scrolls across the display:

TIMESET 01/30 9.15

This example shows that the last time the time or date was set was on January 30 (01/30) at 9:15 am (9.15).

9. Press . The following message scrolls across the display:

PRICESET 01/30 9.42

This example shows that the last time prices were set was on January 30 (01/30) at 9:42 am (9.42).

10. Press  until you have left the function.



VIEW TOTAL UNPAID SALES (NOT SHOWN IF ZERO)

1. Press , then press  until the display shows **_0\$ XX.XX**.



"XX.XX" is the total unpaid sales (free vends, winner vends, 100% discounts, zero price vends) for the entire machine.

2. If desired, view this data by tray and individual selection.



3. Press  until you have left the function.







VIEW TOTAL UNPAID VENDS

1. Press  then press  until the display shows **0 XX "XX"** is the total number of unpaid vends for the entire machine.
2. If desired, view this data by tray and individual selection.
3. Press  until you have left the function.

VIEW NUMBER OF TEST VENDS (NOT SHOWN IF ZERO)

1. Press  then press  until the display shows **151 X**. "X" is the number of test vends.
2. If desired, view this data by tray and individual selection.
3. Press  until you have left the function.

VIEW MACHINE ID NUMBER

1. Press  then press  or  until the display shows **I.D. XXXXXX**. The X's represent the 6-digit machine ID number.
2. You can edit the machine ID number if the SUPERVISOR access code has been previously entered.
3. Press  until you have left the function.



 **TEST VEND SELECTIONS AND VERIFY CREDIT ADDED**





1. Press . The display shows *TEST .00*. You may now test vend selections. If you insert money into the machine, the zeros in the display will be replaced with the amount of the credit. After the item vends, your money will be returned.

NOTE

You may make one more test vend if you close the door while still in TEST VEND mode.

2. Press  until you have left the function.

 **TEST THE DISPLAY**

1. Press , then press  until the display shows *DSPLY TEST*.
2. Press  to light all display segments; press  to turn them off.
3. Pressing a **NUMBER KEY** on the control panel causes all segments to display that character.
4. Press  until you have left the function.



TEST THE ELEVATOR

1. Press , then press  until the display shows **ELEVATOR A**.

(The **A** may be replaced by **B**, **C**, or **D**, depending upon which tray the elevator was sent to during the last test. The presence of a letter in this display means that the elevator is home.)

NOTE

If one dash (-) appears in the display as shown:

ELEVATOR -R

the elevator does not have electrical power because the vend door and/or the cold door is open, and you did not pull out the interlock switch. Pull out the switch and

continue.

If one dash appears in the display as shown:

ELEVATOR -

the elevator is not home. (Two dashes in the display means the elevator is not home and does not have electrical power.)

WARNING

The elevator moves rapidly and with considerable force. Keep away from the moving elevator to avoid injury.

2. Enter the letter of the tray where you want the elevator to go, then press . The elevator moves up to the tray you selected and stays there.

NOTE



As the elevator is activated for this test, the belt selection solenoid for belt 1 is energized (which will vend the production belt #1). To energize a different solenoid, press its number (pressing 3 will energize the solenoid for belt #3). To avoid energizing any solenoid, press 0. No product will be vended.

3. Press  again to send the elevator back down.

4. Press  until you have left the function.





TEST THE SOLENOIDS

1. Send the elevator to one of the trays by following steps 1 and 2 in TEST THE ELEVATOR.
2. Press  until the display shows **SOLENOID**.
3. Test the belt selection solenoids by pressing number keys 1 through 6.
4. Test the elevator stop solenoid by pressing 0.
5. Press  to test all solenoids in sequence.
6. Press  until you have left the function.





TEST THE TRAY MOTOR

1. Press , then press  until the display shows **TRAY.MTR 1-**.
(This display shows that the tray rack is in the HOME position. If the rack is in the VENDED position, the 1 will be replaced by a 2.)

NOTE





If a second dash (-) appears in the display (**TRAY.MTR 1 -**), the tray motor does not have electrical power because you did not pull out the interlock switch. Pull out the switch and continue.

2. Press . The tray motor runs, and the display shows **TRAY.MTR -**
2
3. Press  again to run the tray motor and send the rack back to the HOME position.
4. Press  until you have left the function.







TEST THE DOOR LOCK



1. Press  then press  until the display shows **DOOR.LCK 1.** This display shows that the door lock is in the UNLOCKED position (1), and that the solenoid has power (*). If the door lock is in the LOCKED position, the 1 will be replaced by a -.
2. Press . The door lock solenoid is deenergized, and the display shows **DOOR.LCK -**. (Note that since the solenoid is deenergized, the period (.) is gone from the display.)
3. Press  until you have left the function.

TEST THE DOOR MOTOR



1. Press  then press  until the display shows **DOOR.MTR 1-**. This display shows that the door is in the CLOSED position (1). If the door is in the OPEN position, the display shows **DOOR.MTR -2**.
- NOTE**
- If a second dash (-) appears in the display (**DOOR.MTR - 1-**), the door motor does not have electrical power because you did not pull out the interlock switch. Pull out the switch and continue.
2. Press . The door motor runs, and the display shows **DOOR.MTR -** until the door is in the OPEN position, when it shows **DOOR.MTR -2**.
 3. Press  to close the door.
 4. Press  until you have left the function.



TEST THE COUNTER WHEEL

1. Press , then press  until the display shows *ELEVATOR A*.





(The **A** may be replaced by **B**, **C**, or **D**, depending upon which tray the elevator was sent to during the last test.)

NOTE

If a dash (-) appears in the display (*ELEVATOR - A*), the elevator does not have electrical power because you did not pull out the interlock switch. Pull out the switch and continue.

WARNING

The elevator moves rapidly and with considerable force. Keep away from the moving elevator to avoid injury.

2. Press . The display shows *ELEVA = 00 A*.
3. Enter the letter of the tray where you want the elevator to go, then press . The elevator moves up to the tray you selected, and the two zeros in the display count up in base 16 (hexadecimal).
4. Press  again to send the elevator back down.
5. Press  until you have left the function.



DOWNLOAD DATA TO A PDCD

1. Connect your portable data collection device (PDCD) per its operating instructions.
2. Press . Data is downloaded into your PDCD.

NOTE

Depending upon the setting selected in set **PRINTER OR DEX OPTIONS**, data may be cleared after the download is complete.

3. Press  until you have left the function.



VIEW DIAGNOSTIC MESSAGES

1. Press  the display shows any of the following diagnostic messages, depending upon any fault(s) present:

NOERRORS None of the following errors are detected:

KEYPADXY Key(s) x, y stuck.

ROMERROR Error in the programming EPROM. Machine will not operate.

RAMERROR RAM is not initialized or is not compatible with the currently loaded software. If this message appears, initialize your RAM by performing the following procedure:

NOTE: Initializing RAM will erase all your data settings. Be sure you have written this information down before continuing.



Press **AND HOLD** until two beeps are heard, and the display shows **FINISHED**.

TEMPREF The temperature reference on the main PCB cannot be read.

TEMPSENSE The temperature sensor cannot be read.

TEMPRANGE The temperature sensor is out of range.

NOMECH Coin mech not detected - machine will not operate if configured for coin mech.

MECHCOMM Incomplete coin mech communications -- check harness.

MECHSENSOR Coin mech reporting a bad tube sensor - replace mech.

DEBITCARD Card reader reporting error - machine will not operate if configured for DEBIT ONLY

CHECKRDBV Bill validator reporting error - machine will not operate. Empty stacker, clear jams, etc.

DBVCOMM Incomplete bill validator communications -- check harness.

CHKPRICE Price error detected and changed to maximum - check prices.

CHKCONFIG A PRODUCT CONFIG value was out of bounds and set to nominal - check all PRODUCT CONFIGS.

HEALTHOFF Presently out of service because of a health control temperature error (MAX, xxof). Machine will not operate.



- FOOD01234*** Some errors associated with the food door exists.
- MECH.PAY.JAM** One or more coin tubes are jammed. Pay a coin from each tube until the jam is cleared.
- MECH.ACP.JAM** Coin is jammed in the acceptor section. Check the coin mechanism for a jam in this position. Insert coins and cycle machine power OFF and then ON.
- MECHROM** Replace the coin mechanism.
- MECH.ACCEPT** Coin mechanism acceptor section is unplugged from the main body of the coin mech. Connect the cable and cycle machine power OFF and then ON.
- DBVSENSOR** One of the sensors in the bill validator has failed. The unit will disable itself until the error is corrected. Check for bill stuck in the acceptance path. If no bill is present, replace the validator. Cycle machine power OFF and then ON.
- DBVROM** ROM checksum failure. The unit will disable itself until the error is corrected. Replace the validator.
- DBVJAM** A bill is jammed in the acceptance path. The unit will disable itself until the error is corrected. Remove bill stuck in the acceptance path. Cycle machine power OFF and then ON.
- DBVMOTOR** One of the motors has failed. The unit will disable itself until the error is corrected. Check for bill stuck in the acceptance path. If no bill is present, replace the validator. Cycle machine power OFF and then ON.
- DBVSTACKR** The stacker is open or removed. The unit will disable itself until the error is corrected. Install the stacker correctly.

SET FREEVEND OPTIONS



1. Press  until one of the following is displayed:

FREE OFF - Normal vending mode. No items are on frevend. A closure on the keyswitch input causes the machine to go out of service.

- OR -

FREE ALL - All items are on frevend. The credit display shows

NOMONEYREQUIRED

A closure on the keyswitch causes the machine to go out of service.

- OR -

FREE W/KEY - All items are freevended while there is a closure on the keyswitch input. Normal cash sales are supported when the keyswitch

input is open.

- OR -

FREE ONCE - A closure on the keyswitch input causes only the next item

to be freevended. Coin mechanism errors are ignored. This state is

designed for card or token systems where one item is vended per token.

Normal cash sales are also supported.

2. Press  until the option you want is displayed.

3. Press  until you have left the function.



SECTION III. ADJUSTMENT AND REMOVAL PROCEDURES

ADJUSTING TRAYS FOR TILT PULLOUT

The upper three trays may be set to tilt down as they are pulled out, making food loading easier. Proceed as follows:

1. Remove the tray that is to be adjusted.

WARNING

The food tray assemblies weigh approximately 60 lbs. (27.4 kg.). DO NOT attempt to install or remove a food tray without assistance.

2. Remove the two roller lock assemblies, making note of from which side each was taken.
3. Interchange the roller locks, making sure that the flanges point toward the tray.
4. Attach the roller lock assemblies, using the upper square holes.

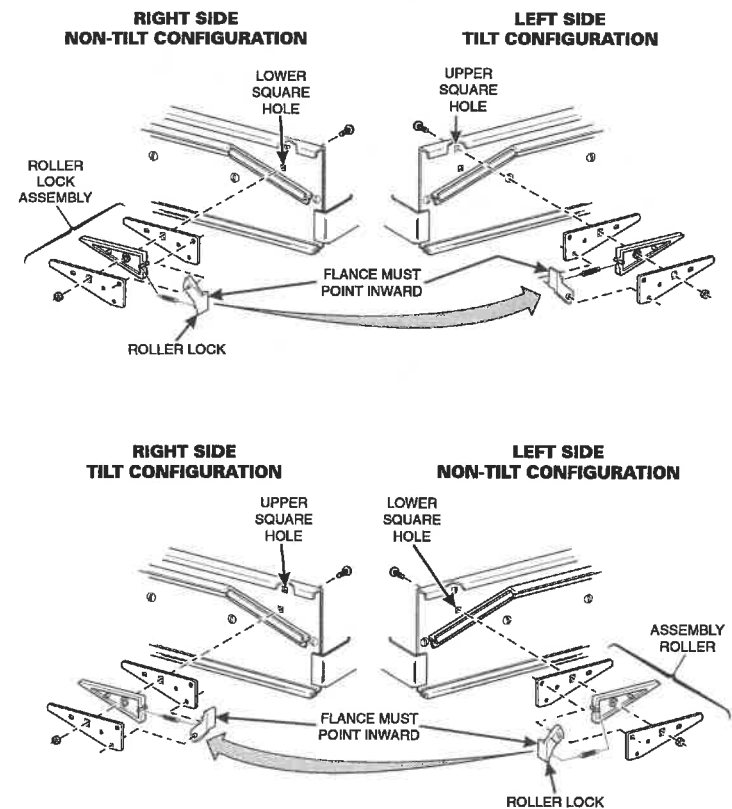

NOTE:
BOTH SIDES OF THE FOOD TRAY MUST BE SET FOR THE SAME TYPE OF CONFIGURATION - BOTH TILT OR BOTH NON-TILT.



ADJUSTING PRODUCT DIVIDERS

Product dividers may be adjusted to accommodate various size products. The dividers have five sets of slots for adjustment, but must be kept parallel to the adjacent belts.

1. Pull the divider forward and lift it out of the front slot.
2. Push the divider back and lift it out of the rear slot.
3. Install a product divider in the reverse of the removal steps.

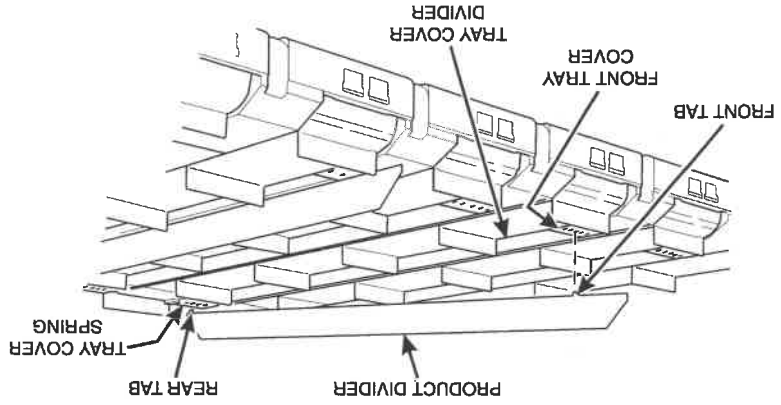



COUPLING TWO MODULES TO VEND TOGETHER

Two adjacent modules may be linked together to vend wider products, provided that the belt divider spacing is the same for both modules. Proceed as follows:

1. Remove the product divider.
2. Push the front tray cover back and lift it up.

CAUTION

Lift the front tray cover as short a distance as possible to avoid possible breakage.

3. Slide the forward sprocket gear all the way to the left.
4. Replace the front tray cover.
5. Turn off the motor for the rightmost of the two modules you linked together. Perform procedures given in BLOCK OR UNBLOCK SELECTIONS in section 2.

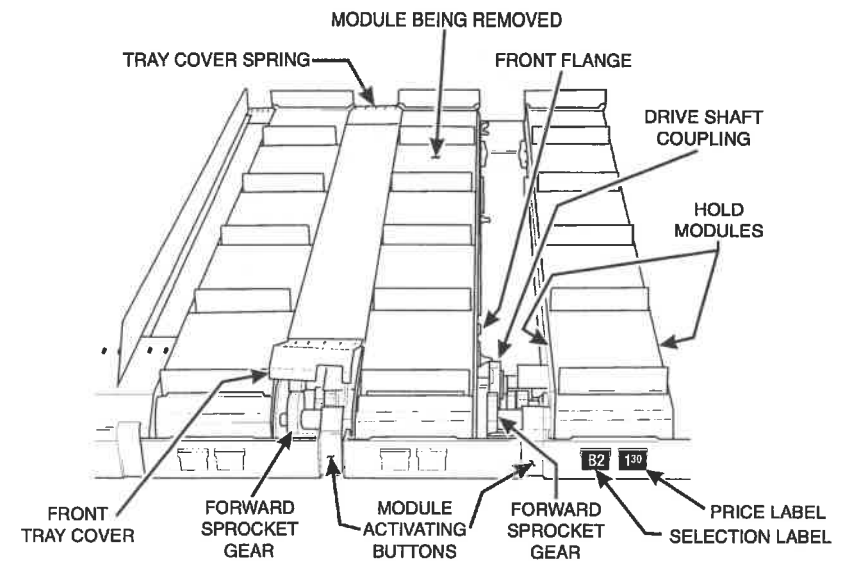



TRAY COVER ASSEMBLY REMOVAL

Proceed as follows:

1. Push up on the forward part of the front tray cover to unfasten it.
2. Push back and lift up on the tray cover assembly. Pull it forward, sliding the assembly over the front flange of the module.
3. Replace the tray cover in the reverse of the removal steps.

NOTE

The tray cover spring may not slide out with the assembly; if not, lift the cover springs straight out.

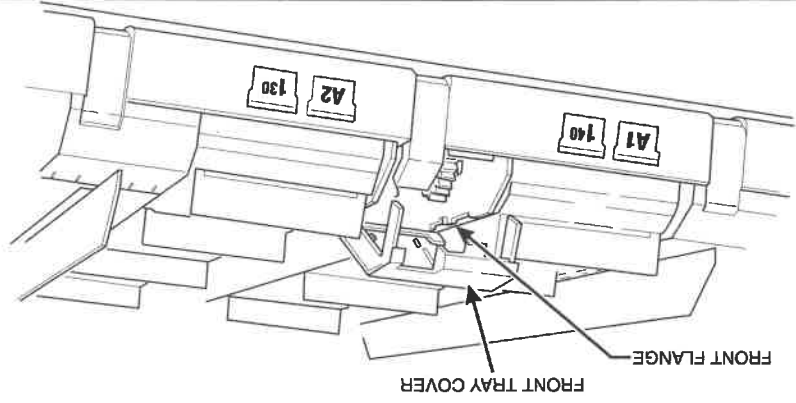
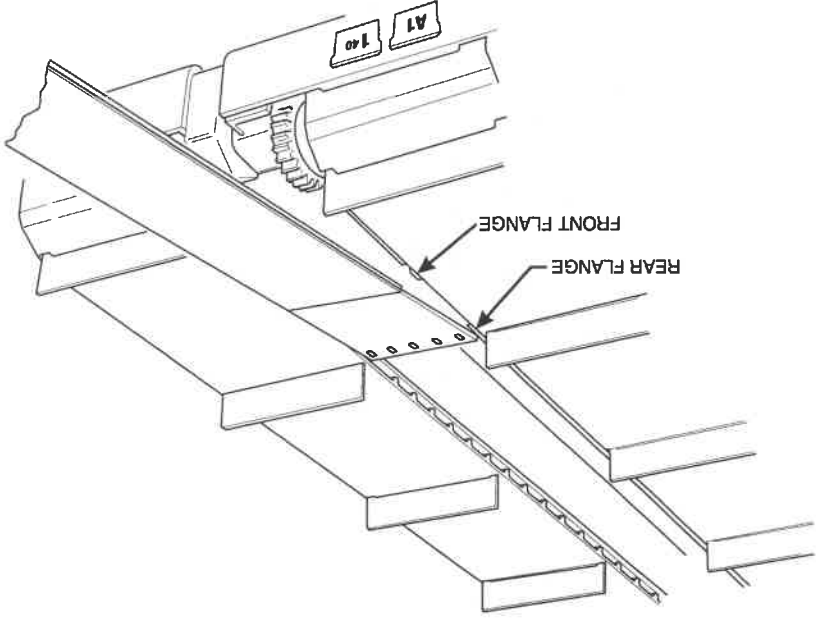



TRAY MODULE REMOVAL AND REPLACEMENT

1. Pull forward the food tray containing the module that is to be removed.
2. Remove the product dividers adjacent to the module.
3. Remove tray cover assemblies.

NOTE

If a module is linked with an adjacent module, slide the forward sprocket gears all the way to the right.

4. Check to see that the drive shaft coupling bar on the tray is in a horizontal position.
5. Lift up the front of the module and pull it out.
6. Replace a module in the reverse of the removal steps, making sure that the module drive shaft coupling is in a vertical position.

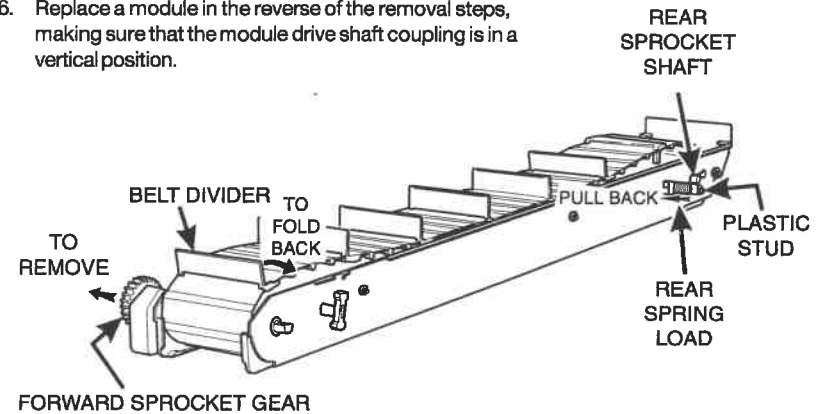

PRODUCT BELT REMOVAL AND REPLACEMENT

Removal

1. Remove the module containing the product belt that is to be removed.
2. Remove the forward sprocket gear.
3. Compress both of the rear spring loads, and rest them against the plastic studs on either side of the module.



4. Near the front of the module, fold back one of the belt dividers.
5. Grasp the belt to the front and back of the folded belt divider and push the belt together.
6. Pull the front section of the belt up and towards you. The belt will come apart.
7. Remove the belt divider.

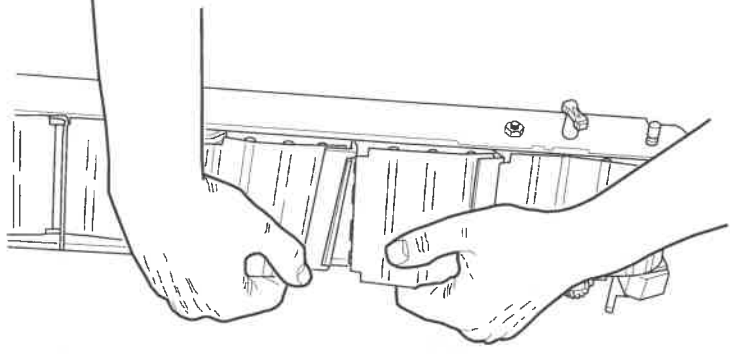
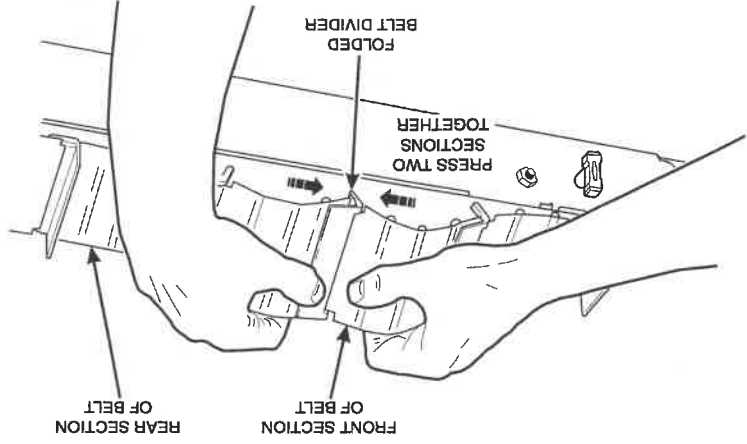



- Place the palm of your hand on the front section of the belt to guide the belt through the module. Pull forward on the back section of the belt to remove it from the module.

CAUTION

Always pull the product belts in a forward direction; on the top side, from the rear of the module to the front. Never pull the belts backwards; from the front of the module to the rear. Pulling them backwards can break the belt dividers.

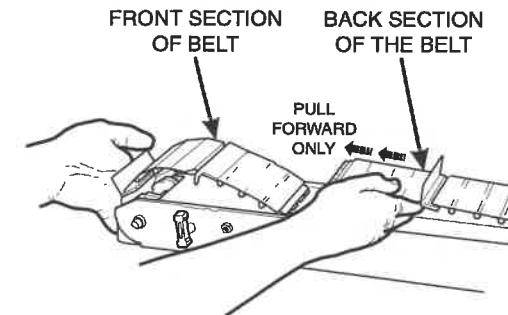

Replacement

- Lay the product belt on the top of the module so that the belt dividers will fold back, not forward.
- Turn the front sprocket shaft so that its flat side is facing straight up.
- Place the first rib on the belt into the top dwell position on the front sprockets.

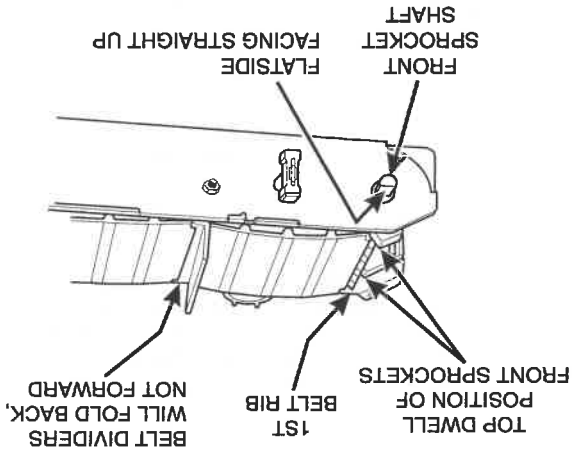

4. Holding the belt in place on the front sprockets, stand the module on its rear end and carefully thread the belt through the front of the module (figure 3-9).
5. Pull the belt through the module until it reaches the rear rollers.

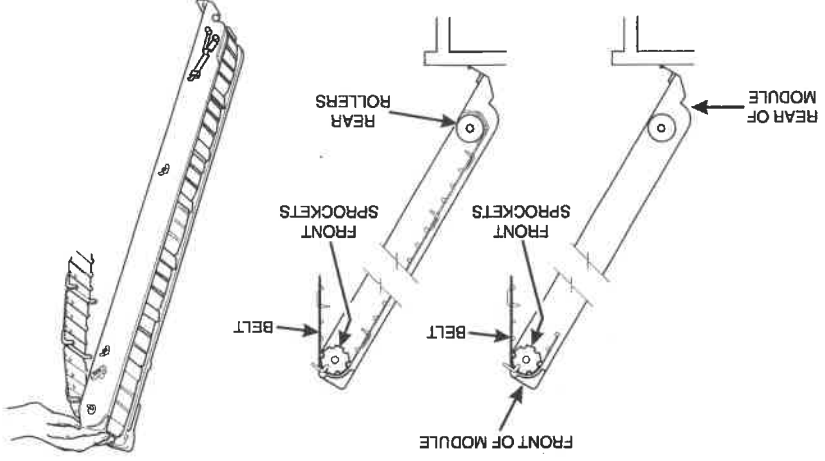

6. Lay the module down and pull the belt around the back of the rear rollers until about 6 inches (15.2 cm) of the belt protrudes from the top of the module.
7. Move the rear shaft to its forward limit.
8. Align the rear rollers so that the right rear roller is positioned between the guide tabs on the belt.

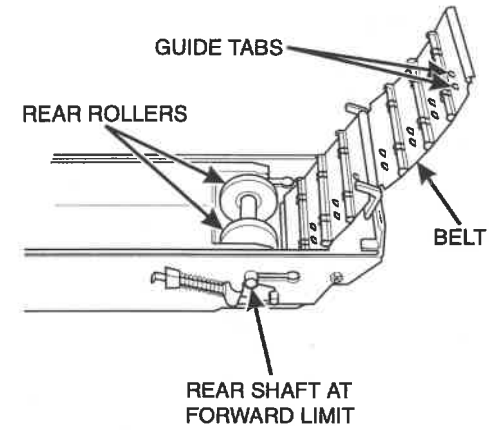

9. Grasp both ends of the belt and pull them together (figure 3-11).
10. Insert the tabs on the front section of the belt into the pockets of the rear section of the belt and snap the belt together.

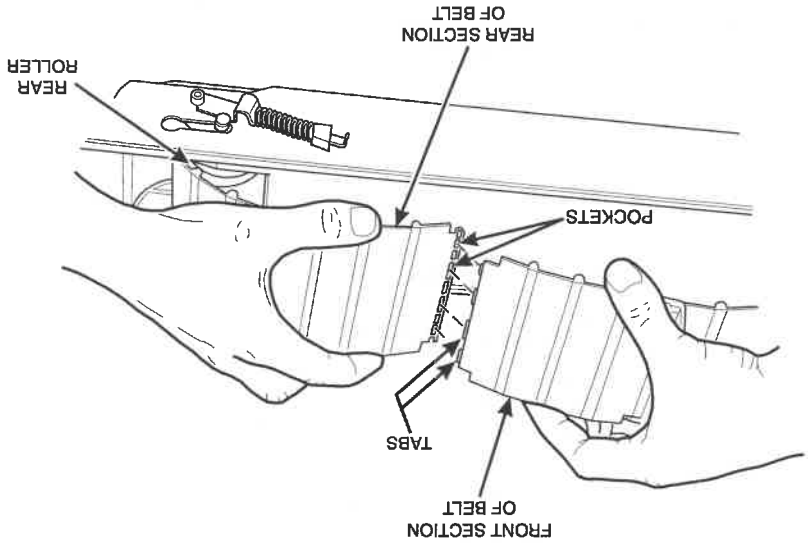

11. Compress both of the rear springing loads and place them in the grooves on the rear sprocket shaft.
12. Rotate the belt in a forward direction to check for smooth operation.
13. If the belt operates properly, skip to step 15.

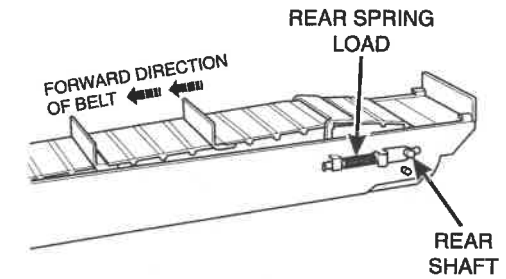

14. If the belt does not operate smoothly, it is not seated properly on the forward sprockets. To correct this:
 - a. Lift the product belt up near the front of the module.
 - b. Reach under the belt and place the right forward sprocket between the guide tabs on the belt.
 - c. Turn the forward sprockets until the ribs on the belt fit into the dwells on both forward sprockets.
 - d. Lower the belt onto the module.
 - e. Rotate the belt in a forward direction to check for smooth operation.
15. Replace the belt divider by inserting the belt divider prong on one side of the blade into the belt rib hole, then insert the other side. Install the divider so that it folds back, not forward.

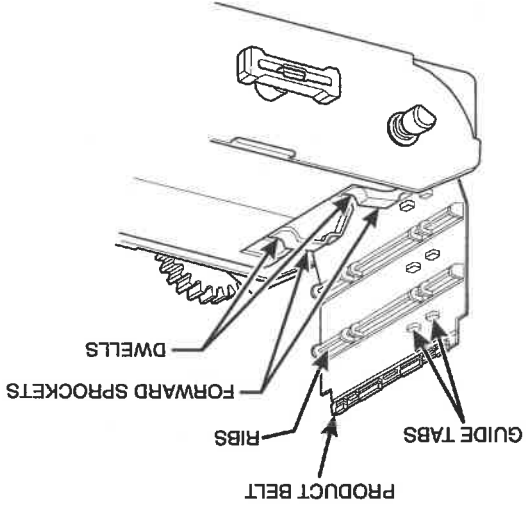

16. Rotate the belt forward until the flat side of the front sprocket shaft faces straight up and a belt divider is positioned as shown.
17. Rotate the drive gear in either direction until it locks.
18. Slide the forward sprocket gear onto the front sprocket shaft. It may be necessary to rotate the gear until it slides on; the gear will go on, only in one position. **DO NOT** rotate the front sprocket shaft while installing the forward sprocket gear.
19. Replace the module in the food tray from which it was removed.
20. If the module you just replaced was linked to the module on its left, move its forward sprocket gear to the left against the left-hand module.
21. If the module you just replaced was linked to the module on its right, move the forward sprocket gear on the right-hand module to the left, against the module you just replaced.



SECTION IV. CLEANING, SANITATION, AND SERVICE

INTRODUCTION

The information in this section will explain how to clean, sanitize, and service the merchandiser on a day-to-day basis. Cleaning and sanitation are an important phase of merchandiser operation and anyone who services vending machines must use proper cleaning and sanitizing procedures. A clean and well maintained merchandiser will provide a better product and greater safety for your customers.

The periods and suggested procedures for service and sanitation are daily, weekly, and monthly. These periods and procedures are given as guides only and are not to be construed as absolute or invariable. Location conditions and merchandiser vending volume must always be considered. Certain installations require that some or all of the steps under weekly service and sanitation be performed daily, and those under monthly service and sanitation be performed weekly, etc. Each merchandiser must be maintained individually in accordance with its particular requirements.

CLEANING AND SANITIZING - WHAT'S THE DIFFERENCE?

CLEAN means "free of visible soil". In vending machines, servicing and cleaning is done to maintain product quality and to remove food soils, oils, and mineral strains that could affect product taste, aroma, and appearance.

SANITIZING means the reduction to safe levels of the number of disease-causing bacteria that remain on the surface **after** cleaning. Therefore, cleaning and sanitizing are done in separate steps, as prescribed by health regulations and good industry practice.

When you sanitize you create a healthy and hygienic condition. This leads to wholesome food, which in turn leads to satisfied customers.

SANITIZING IS NO SUBSTITUTE FOR GOOD CLEANING

How do I sanitize?

You can sanitize by using either of these two methods:

Chemical: The object to be sanitized is treated with a bactericidal compound.

Heat: Raise the temperature of the object to be sanitized high enough to kill bacteria. Immersion for at least 30 seconds in clean hot water at a temperature not lower than 170° F (77° C) is effective.

In any case, the object to be sanitized must be thoroughly clean and completely rinsed in order for the sanitizing process to work. Caked-on soils not removed by cleaning, for example, may shield bacteria from a sanitizing solution.



CAUTION!

Do not get electrical connections or electrical components wet. Do not use wax or lubricants which contain silicone on or in the merchandiser. Silicone or silicone vapors can cause electrical failures.

Set the main switch to OFF before cleaning or servicing the merchandiser.

Be sure the area is well ventilated and no open flames are present before using any aerosol spray.

Use protective glasses or a protective shield if an air hose is used for cleaning or drying.

DAILY SERVICE PROCEDURES

- Replace burned out or discolored display lamps.
- Replenish coin tubes in the coin mechanism.
- Remove and empty the condensate pan if necessary.
- Follow the daily cleaning and sanitation procedures and then reload the merchandiser.
- Empty the bill validator as shown below.

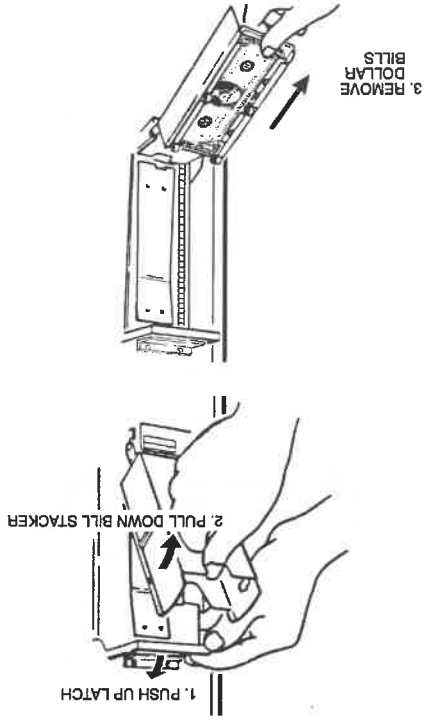



DAILY CLEANING AND SANITATION PROCEDURES

- Remove all past-date merchandise from the merchandiser.

WARNING

The food tray assemblies weigh approximately 60 lbs. (27.4 kg.). DO NOT attempt to install or remove a food tray without assistance.

- Check for liquid spillage on the tray modules. If spillage has occurred, remove the affected module(s), then wash and sanitize them with a clean, damp disposable paper wiper or a clean soft-bristle brush. Rinse with clean hot water and dry thoroughly. Replace the module(s).
- Check for liquid spillage on the elevator tray. If spillage exists, remove the tray (which is held in place by three thumbscrews). Wash and sanitize the tray with a clean, damp disposable paper wiper or a clean soft-bristle brush. Rinse with clean hot water and dry thoroughly. Replace the elevator tray in the reverse order of removal.
- Clean the display glass on the cabinet door.
- Wipe the exterior of the merchandiser with a damp disposable paper wiper and dry thoroughly.
- Fill the appropriate columns on the record of cleaning card.

WEEKLY SERVICE PROCEDURES

- Follow the daily service procedures.
- Inspect and clean the lint screen located below the food compartment, if needed.
- Inspect the coin mechanism and bill validator. Clean if necessary.

WEEKLY CLEANING AND SANITATION PROCEDURES

- Follow the daily cleaning and sanitation procedures.
- Inspect the merchandiser for overall cleanliness, especially in corners.
- Clean the glass on the inner door inside and out.
- Fill in the appropriate columns of the record-of-cleaning card.

MONTHLY SERVICE PROCEDURES

- Perform the weekly service procedures.
- Clean the coin chute and coin validator. See **CLEANING THE COIN VALIDATOR AND COIN CHUTE** in this section.
- Clean the bill validator. See **CLEANING THE BILL VALIDATOR** in this section.
- Inspect the condenser vent screen on the rear of the merchandiser and clean if necessary with a vacuum cleaner or soft-bristle brush.

CLEANING THE COIN VALIDATOR AND COIN CHUTE

1. The coin validator and coin chute should be inspected at regular intervals and cleaned on approximately a monthly schedule.
2. Remove the coin validator assembly from the merchandiser and clean the coin chute with a tube cleaning brush to remove any accumulated dust and foreign matter.
3. Clean the coin validator thoroughly or replace the assembly with a clean unit from the shop. The coin validator can be cleaned with detergent and hot water, but it has to be completely dry before it is replaced in the merchandiser.

CLEANING THE BILL VALIDATOR

Clean the optional bill validator as follows:

WARNING
 Never use water or spray lubricants to clean the bill validator. Be sure power is disconnected before proceeding.

1. Set the MAIN POWER switch to the OFF (down) position, or unplug the merchandiser.
2. Clean the bill insertion opening with a mild detergent (view A).
3. Periodically open the bill validator and inspect the magnetic heads. (Open the bottom latch.) If the heads appear dirty, clean them with a cotton swab moistened with a small amount of denatured alcohol (view B). Re-wipe clean the rollers and belt. Remove any foreign matter. Inspect the latches and levers for smooth operation (view C).
5. Connect the main power and test vend the merchandiser for acceptance of genuine dollar bills.

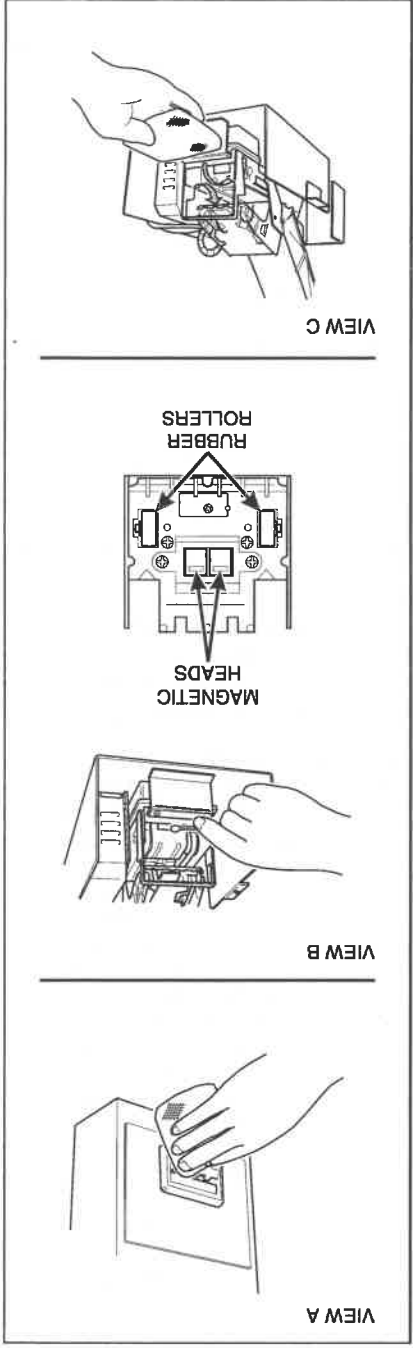



INDEX

A

Adjustments	
Product Dividers	54
Trays	9
Trays for Tilt Pullout	53

B

Baud Rate	19
Belt (See Product Belt)	
Bill Validator	
Cleaning	68
Options, Select	21
Set Up	9
Block Selections	37

C

Card Reader and Options, Select	23
Cleaning	65
Bill Validator	68
Coin Chute	67
Coin Validator	67
Daily	67
Weekly	67
Clearing	
Paid Sales Data	39
Resettable Data	39
Code, Supervisor, Enter	17
Coin	
Box, View Amount in	39
Chute, Cleaning	67
Mechanism, Install	4
Mechanism, Select	20
Payout	36
Validator, Cleaning	67
Connect the Merchandiser to Utilities	2
Counter Wheel, Test	49
Coupling Two Modules	55
Credit, Verify	45
Custom Messages, Edit	33

D

Daily	
Cleaning Procedures	67
Sanitation Procedures	67
Service Procedures	66



Data

39 Clear All Resetttable

19 Clearing Access, Lock or Unlock

49 Download to a Pcd

39 Paid Sales, Clear

42 Time, View

38 View Three Different Ways

27 Day of the Week, Set

28 Day, Set

18 Dex Options, Set

50 Diagnostic Messages, View

41 Discount Sales by Time Interval, View

11 Displays

22 Language, Select

45 Test

Door

3 Lock Installation

48 Lock, Test

48 Motor, Test

49 Download Data to a Pcd

3 Drive Shaft Channels, Home

E

33 Edit Custom Messages

1 Electrical Utility Requirements

46 Elevator, Test

17 Enter a New Supervisor Code

F, G

13 Flow Charts

Freewend

32 Message, Select

52 Options, Set

40 Sales by Time Interval, View

41 View

11 Function Keys

H

7 Hatch Shell, Install

3 Home the Drive Shaft Channels

I

44 ID Number, View

1 Inspect

Install

4 Coin Mechanism

7 Hatch Shell

9 Selection and Price Labels

6 Trays



K

Keys

Function	11
Other	11

L

Language, Select	22
Level the Merchandiser	2
Load Product	9
Lock	
Data Clearing Access	19
Door, Test	48
Mode or Payout Keys	18

M

Machine Id Number, View	44
Message	
Custom, Edit	33
Diagnostic, View	50
Freevend, Select	32
Out-of-Service, Select	31
Standby, Select	31
Mode Keys, Lock or Unlock	18
Modules, Coupling	55
Monetary Options, Select	23
Month, Set	28
Monthly Service Procedures	67
Motor	
Door, Test	48
Tray, Test	47

N

Nonresettable Data	
Sales, View	37
Vend, View	37

O

Open Tray Interlocks	5
Out-of-Service Message, Select	31

P, Q

Paid Sales Data, Clear	39
Paid Vends, View Total	38
Payout Coins	36
Payout Keys, Lock or Unlock	18
Pdcd, Download Data to	49
Perform Test Vends	9
Position the Merchandiser	2



Price Labels, Install 9

Prices

Set 9, 33

View 33

Printer

Baud Rate, Select 19

Options, Set 18

Product Belt

Removal 57

Replacement 57

Product Dividers, Adjusting 54

Product, Load 9

Programming 10

Flow Charts 13

R

Removal

Product Belt 57

Tray Cover Assembly 56

Tray Module 57

Replacement

Product Belt 57

Tray Module 57

Tray Module

Resettable Data, Clear All 39

S

Sales

Data, View 37

Total Paid, View 38

Unpaid, View 43

Sanitation

Procedures, Daily 67

Procedures, Weekly 67

Select

Bill Validator and Options 21

Card Reader and Options 23

Coin Mechanism 20

Display Language 22

Freevend Message 32

Monetary Options 23

Out-of-Service Message 31

Standby Message 31

Selection Labels, Install 9

Selections

Block or Unblock 37

Test Vend 45

Service

Procedures, Daily 66

Procedures, Monthly 67

Procedures, Weekly 67



Settings

- Bill Validator 9
- Day of the Week 27
- Dex Options 18
- Freevend Options 52
- Month, Day, and Year 28
- Prices 9, 33
- Printer Options 18
- Temperature 26
- Time 9
- Time of Day 27
- Time-of-Day Discount Vending 28
- Time-of-Day Free Vending 28
- Time-of-Day Inhibited Vending 28
- Winner Mode 25
- Software Version, View 26
- Solenoids, Test 47
- Standby Message, Select 31
- Supervisor
 - Code, Enter 17
 - Mode 17

T

Temperature

- Set 26
- View 35

Testing

- Counter Wheel 49
- Display 45
- Door Lock 48
- Door Motor 48
- Elevator 46
- Solenoids 47
- Tray Motor 47

Test Vend

- Perform 9
- Selections 45
- View 44

Time

- Data, View 42
- Interval Editing 29
- Set 9

Time-of-Day

- Discount Vending, Set 28
- Free Vending, Set 28
- Inhibited Vending, Set 28
- Set 27

Total Paid Sales, View 38



Tray 9

Adjusting for Tilt Pullout 53

Cover Assembly Removal 56

Install 6

Module Removal 57

Module Replacement 57

Motor, Test 47

U

Unblock Selections 37

Unlock Data Clearing Access 19

Unlock Mode or Payout Keys 18

Unpack 1

Unpaid Sales, View 43

Unpaid Vends, View 44

Utilities

Connect the Merchandiser to 2

Requirements 1

V

Validator, View Amount in 40

Vend

Data, View 37

Unpaid, View 44

View Total 38

Verify Credit Added 45

View

Amount in Coin Box 39

Amount in Validator 40

Data Three Different Ways 38

Diagnostic Messages 50

Discount Sales by Time Interval 41

Free Vends 41

Freevend Sales by Time Interval 40

Machine ID Number 44

Machine Temperature 35

Machine Maximum/Minimum Prices 33

Nonresetttable Sales Data 37

Nonresetttable Vend Data 37

Number of Test Vends 44

Software Version 26

Time Data 42

Total Paid Sales 38

Total Paid Vends 38

Total Unpaid Sales 43

Total Unpaid Vends 44

Winners 41



W, X

Weekly
Cleaning Procedures 67
Sanitation Procedures 67
Service Procedures 67
Winner
Mode, Set Up 25
View 41

Y, Z

Year, Set 28